



## ALTICO SERVICE BULLETIN

**#ASB 060700**

**DATE:** JUNE 7, 2000

**SUBJECT:** STIFFENER IN TOP FLAP OF DOLPHIN MAIN CONTAINER

**STATUS:** **MANDATORY:** Inspection of all DOLPHIN harness/container systems manufactured prior to February 2000.

**MANDATORY:** Update if subject condition found.

**RECOMMENDED:** Update all DOLPHIN's to prevent occurrence of subject condition.

**IDENTIFICATION:**

All DOLPHIN harness/container systems manufactured prior to February 2000.

**BACKGROUND:**

On the underside of the top flap of the main container, the corners of an unreinforced stiffener may wear through the fabric covering. Although this condition may easily escape notice during normal repacking, the exposed corner can catch a suspension line, producing a horseshoe malfunction. One such incident was reported December of 1999, with the reserve fortunately deploying through the malfunctioned main which remained caught by a suspension line after a cutaway had been attempted. In May 2000 a report was received that a rigger had noticed this condition during a routine inspection/repack, and the exposed corner was covered prior to the next jump.

In January 2000, Altico changed the design of the top flap, adding a

reinforcing tape to the underside of the main top flap which greatly reduces the possibility of stiffener "wear-through."

**BULLETIN:**

Before Next Jump: Inspect any DOLPHIN system manufactured prior to February 2000. Determine if reinforcing tape is present. If not present, determine if the stiffener has worn through. If a corner of the stiffener is exposed, it is MANDATORY that this condition be corrected before the next jump. This repair/update may be performed by a suitably qualified rigger according to the instructions which follow, or by Altico.

It is recommended that any DOLPHIN be updated in this manner to prevent the occurrence of stiffener wear-through. It is not critical if the fabric shows no wear, but the corners of the stiffener should be inspected before every main repack.

**MINIMUM TOOLS REQUIRED:**

- 1) Sewing machine capable of sewing through the plastic stiffener and its fabric coverings
- 2) Hot knife
- 3) Thread-nipper or scissors

MATERIALS:

- 1) One-inch Type IV tape, minimum length 9"
- 2) Nylon E-Thread

**AUTHORITY:**

MICHAEL FURRY, President  
ALTICO  
35870 CLINTON AVE.  
DADE CITY, FL 33525  
TEL (352) 523-0052  
FAX (352) 523-1229  
E-MAIL: alticon@aol.com  
WEBSITE: www.altico.com

**INSPECTION AND REPAIR/UPDATE OF DOLPHIN MAIN TOP FLAP IN COMPLIANCE WITH SERVICE BULLETIN #ASB 060700**

- 1) Inspect underside of main top flap at points indicated in FIG. 1. If a corner of the plastic stiffener is exposed by wear, proceed to step 2.

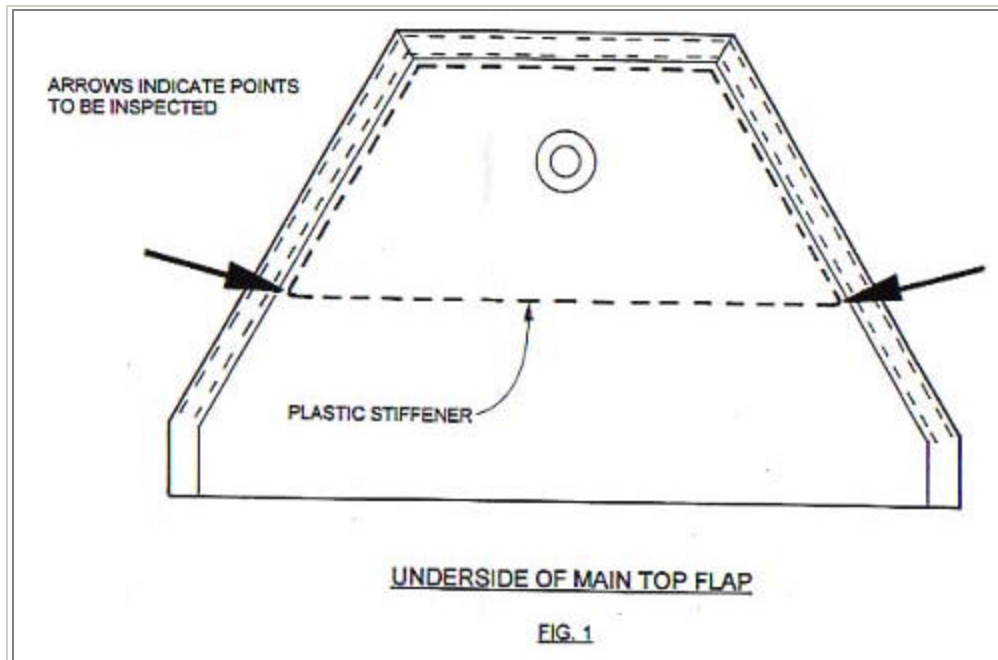

2) With a hot knife, cut a piece of 1" Type IV tape as shown in FIG. 2.

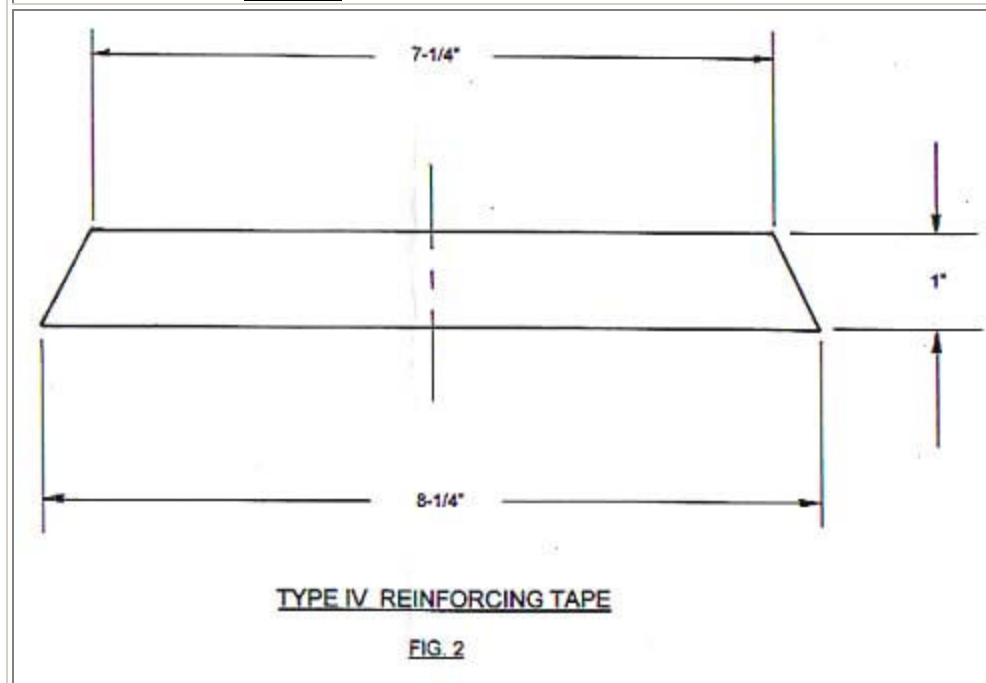

3) Remove the stitches from a 1-3/4" (approx.) section of binding tape along each side of the main top flap. The section of removed stitches must be centered on the edge of the stiffener as shown in FIG. 3. This is done so that the ends of the reinforcing tape may be installed under the binding tape.

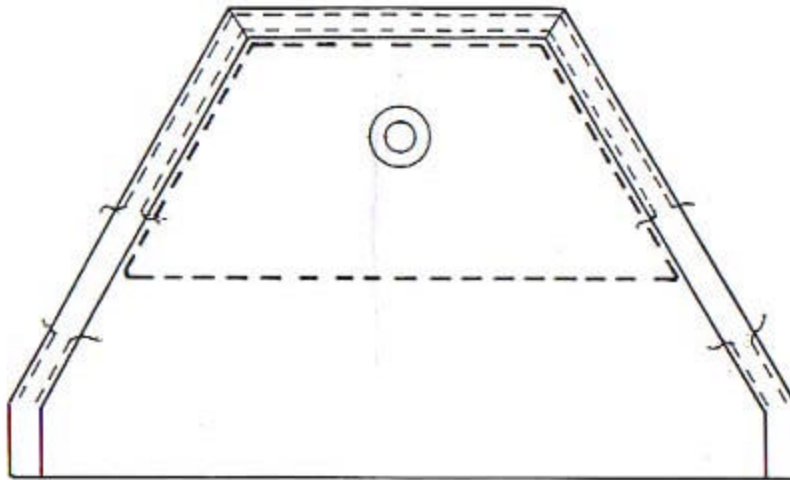

**FIG. 3**

4) Center the prepared piece of 1" Type IV tape over the edge of the stiffener and stitch as shown in **FIG. 4**.

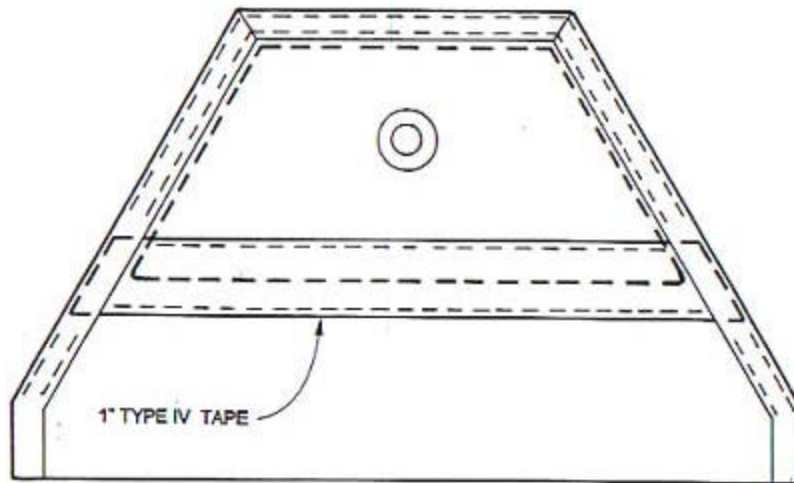

**FIG. 4**

5) Replace the stitching in the binding, covering the ends of the Type IV reinforcing tape and oversewing approx. 1" on each side.

The manufacturer of the DOLPHIN offers the update described in Service Bulletin #ASB 060700 for a price of \$30, plus return shipping. Turnaround time for this type of customer service is normally one day. To take advantage of this offer, strip the harness/container of all components not permanently attached and send it to:

ALTICO  
35870 CLINTON AVE.  
DADE CITY, FL 33525  
U.S.A.

Include a note requesting the work to be done, and be sure to provide a return shipping address. Payment may be made by Visa or Mastercard; otherwise the rig will be shipped C.O.D.

For further information call (352) 523-0052, FAX (352) 523-1229, or e-mail [alticon@aol.com](mailto:alticon@aol.com).

**Questions about  
Altico's Products:**  
[alticon@aol.com](mailto:alticon@aol.com)

**Questions for this  
page's Webmaster:**  
[altico@earthlink.net](mailto:altico@earthlink.net)

Date this document last updated: 3/2/03