

Jump Shack

1665 N. Lexington Ave. #106 • DeLand, FL 32724-2187
(904) 734-5867 • FAX (904) 734-8464

July 19, 2005

Product Service Bulletin

Issue date: 1/01/01

Bulletin number: 1-01-01

Subject: Reserve Suspension Line Stows

Status: Strongly Recommended

Identification: All Racer Reserve Free Bags

Background: In consideration of the recent structural failures of some reserve canopies and as a result of our continuing testing of deployment methods Parachute Labs., Inc. dba Jump Shack has decided to upgrade the method of stowing lines on our Reserve Deployment Bags ("Free Bags"). The phenomenon of line strip a.k.a. line dump, has been known for a number of years. The solution to this problem - *Military Specification Stow Bands and proper line stow balance* - has now been used in the field, on main canopies and a few reserves, for a time adequate to provide confidence in the soundness of the solution.

Additionally, a study of the retention forces provided by the "Safety Stow" has shown that it is impossible to attain a balanced releasing force of these locking stows. This alone is enough to indicate the potential of locking stow line dump - either single or both sides. Mathematical calculations of the retaining force of the line stow pouch Velcro retainer when compared to the forces generated by the mass of the stowed lines during snatch, indicate a potential for these lines to also dump.

Parachute Labs., Inc. has been using this new configuration on select models for some time now and it is currently covered in the Racer Owners Manual. The original certification of the Ram Air Reserve in the Racer was performed using this configuration.

Service bulletin:

Effective immediately all Racer Reserve Free Bags should have the method of stowing the reserve canopy suspension lines modified to this bulletin. To accomplish this requires 2 steps. One for the Locking Stows and one for the rest of the lines.

For the Locking Stows: All Racer Free Bags manufactured in the last 8 years have been equipped with a "hesitator loop" for the attachment of Mil. Spec. Rubber Stow bands for the locking stows. These loops may be employed or the rubber band can simply be attached to the grommet previously used for the "Safety Stow Elastic" which should be discarded.



For the remaining line stows: Remove the existing line stow pouch and the attendant Velcro. This may be done by simply removing the lateral retaining stitches and cutting the fabric away from the edge along the binding tape. Center a six (6") inch long one (1") wide piece of Type 4 Pebble (Square) Weave to the inside of the closing flap on a line one fourth (1/4) of the width of the bag in from the outer edge beginning half way (50%) from the edge of the locking stow grommet reinforcement toward the back side of the bag (location-wise, just like we currently construct our main deployment bag). Roll the cut ends under one half (1/2") inch and secure with a Fed. Std. 751 Type 301 locking stitch around the perimeter with an over stitch of 1 inch. Do this to both sides to provide a left and right stow reinforcement location. This will provide a backing for the hesitator loops applied in the next step.

On the outside of the closing flap attach a six (6") inch piece of Type 3 Ribbon Weave (Binding Tape) to the Square weave location (through the bag fabric), applied in the previous step. Secure this tape on each end and in the middle with a Fed. Std. 751 Type 308 Stitch or a Bar tack two inches (2") apart after folding the cut end under one half (1/2") inch. Some slack should be left between the stitches for easy installation of the Rubber Stow bands.

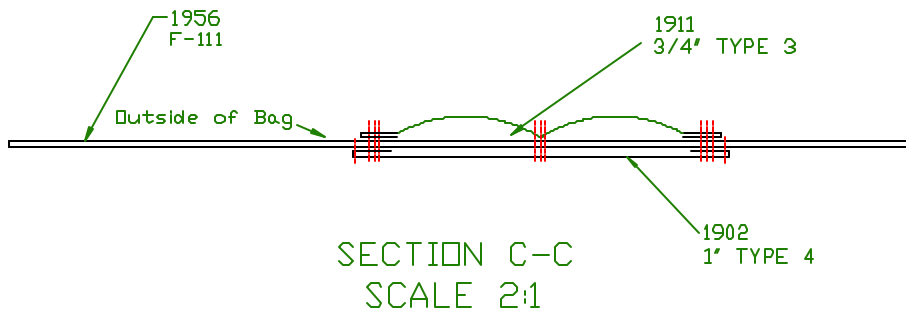
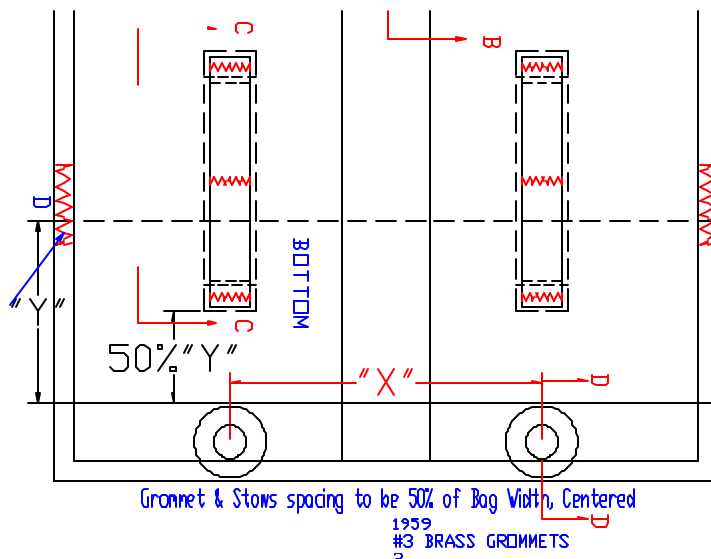

Install Rubber Stow Bands which comply with Military Specification R-1832 to the Grommet or hesitator loop described in "For Locking Stows," and on the Type 3 provided, for the remaining stows. The number of stows depend on the bag width and line length. The size of the rubber bands should be defined by the canopy manufacturer and depends on the line type and diameter.

When packing, the line stow bights should extend to the edge of the bag.

Riggers should inspect the rubber band for deterioration at each inspection cycle and replace as necessary.

Compliance date:

Optional

Authority:

John B. Sherman
Jump Shack
John@Jumpshack.com

Distribution:

Parachute Industry Association, Technical Committee
United States Parachute Association, Safety & Training Committee
IPC Technical Committee
All Parachuting Publications
All Parachute Riggers
All Drop Zones

