



An alle Vereine /Schulen/ Fallschirmtechniker / Fallschirmwarte

## SICHERHEITSMITTEILUNG für Gurtzeuge

- herausgegeben: 03. März 2021  
Nummer: 2021-02 SM UPT SE Reserve-Klappe Instruct 065 Rev 0  
Bezug: Bulletin: Instruct 065 Rev 0 Vector V3SE Reserve Pin Cover Replacement  
( Die SM 2021-01-A - Erweiterung der Instruct 064 auf Rev. 1 behält Ihre Gültigkeit )  
Grund: Verzögerung der Öffnung der Reserveklappen an den betroffenen SE  
Betroffene Muster: Vector SE von UPT mit der Containergröße  
SE 360-1 SE 360-2, SE 360-3, SE 361, SE 364 and SE 364-1  
Betrifft die angegebenen Vector SE,  
hergestellt zwischen Mai 2013 - Jan. 2021  
Status: verpflichtende Maßnahme  
Maßnahmen: Austausch der Abdeckklappe  
Durchzuführen bis: spätestens beim nächsten Check / Reserve packen  
Durchzuführen von : Masterrigger / Fallschirmtechniker  
Bemerkungen: sinngemäße Übersetzung Teile des Textes aus dem Anschreiben von UPT:  
...Gemäß der beiliegenden Anleitung ist diese Modifikation zwingend vor dem  
nächstens Packen der Reserve erforderlich. Die Kosten für den Tausch der  
Klappe übernimmt UPT bis zu einer Höhe von 35.-\$. Unter Angabe der  
Seriennummer und Bankverbindung kann man eine Rechnung an UPT -  
[VectorSE@uptvector.com](mailto:VectorSE@uptvector.com) senden. Alternativ kann man die Summe bei UPT für  
zukünftige Einkäufe gutschreiben - bitte vermerken Sie in diesem Fall auf der  
Rechnung "credit my UPT account" .....  
--- Im Anhang die originale Datei von UPT ---  
**Wichtig : Ohne Modifikation KEIN Sprung:**  
**Entweder die Field Repair SM 2021-01 A durchführen oder**  
**sofort bzw. spätestens beim nächsten Repack die Klappe tauschen.**  
Dokumentation: 1. : Datum - UPT 065 SE Klappe durchgeführt - Name - Stempel - Sign  
2. : Mitteilung per Mail an : [VectorSE@uptvector.com](mailto:VectorSE@uptvector.com) über die durchgeführte  
Arbeit mit der dazu gehörenden Seriennummer des Gurtzeuges  
Verteiler: Techniker, Warte, Händler, Vereine, Sprungzentren.



## Vector Student SE Replacement Flap Process

17 February 2021

Please follow these steps regarding the reserve flap notice for Vector Student SE containers with a DOM between May 2013 – January 2021, in the following sizes - SE 360-1 SE 360-2, SE 360-3, SE 361, SE 364 and SE 364-1.

### Field Modification

Per the included instructions, this field modification is mandatory if you wish to use your SE containers prior to installing the new reserve flap at the next repack cycle.

### Reserve Flap Replacement

At the next repack cycle, please replace the reserve flap with the new one provided by UPT, following the included work instructions.

### Confirm Replacement

It is important that we keep an accurate record of SE's that have the new flap installed. Once the work is completed, please email a confirmation including serial numbers to [VectorSE@uptvector.com](mailto:VectorSE@uptvector.com).

### Rigging Costs

UPT will cover the rigging costs on this work up to a total of \$35 per SE container if needed. Please send an invoice to [VectorSE@uptvector.com](mailto:VectorSE@uptvector.com), detailing serial numbers and your banking details on the invoice. Alternatively, we can credit your account at UPT for use on future purchases – please note 'credit my UPT account' on the invoice if you wish to do this.

**Please note, both field modification and reserve flap replacement must be completed by an FAA Master Rigger, or foreign equivalent.**

We thank you for your patience and understanding in this matter.

## SALES DEPARTMENT

1645 LEXINGTON AVENUE ♦ DELAND FL 32724-2106 ♦ TELEPHONE +1 386 736 7589 ♦ FAX +1 386 734 7577  
WWW.UPTVECTOR.COM



## VECTOR 3SE RESERVE PIN COVER FLAP REPLACEMENT

### Overview

Removal and replacement of the Vector3SE Reserve Pin Cover Flap.

This work must be performed by an FAA Certified Master Rigger or foreign equivalent.

Please notify UPT once this work has been completed.

### Machines/Tools required

Single needle 301 sewing machine

Bartack machine - 42 stitch

Zig zag – 304 or 308 (optional)

Snips or scissors

Seam ripper

Lighter

Pliers

Screwdriver

Awl (optional)

Clamping tool for clamp (optional).

### Materials Supplied by UPT

1 x Replacement Reserve Pin Cover (RPC)

1 x Housing Clamp P/N: MIS-H-1EAR CLAMP

1 x 9/16" Type-webbing

### Optional

Wax handmaking thread (not supplied by UPT)

## ENGINEERING DEPARTMENT

1645 LEXINGTON AVENUE ♦ DELAND FL 32724-2106 ♦ TELEPHONE +1 386 736 7589 ♦ FAX +1 386 734 7537

UPT@UPTVECTOR.COM ♦ WWW.UPTVECTOR.COM

INSTRUCT-065 V3SE Reserve Pin Cover Installation.doc

**Procedure**

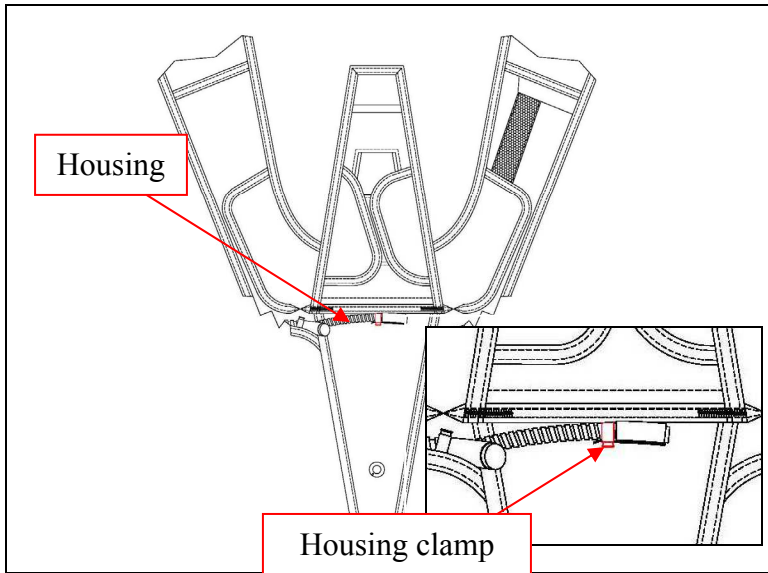

Before removing the Reserve Pin Cover flap that is being replaced, the housing needs to be detached from the clamp that secures it to the housing anchor loop.

This can be done using a screwdriver and an awl (or similar tools) to carefully pry open the clamp until the housing is free to move.

Discard the old clamp and Type-1

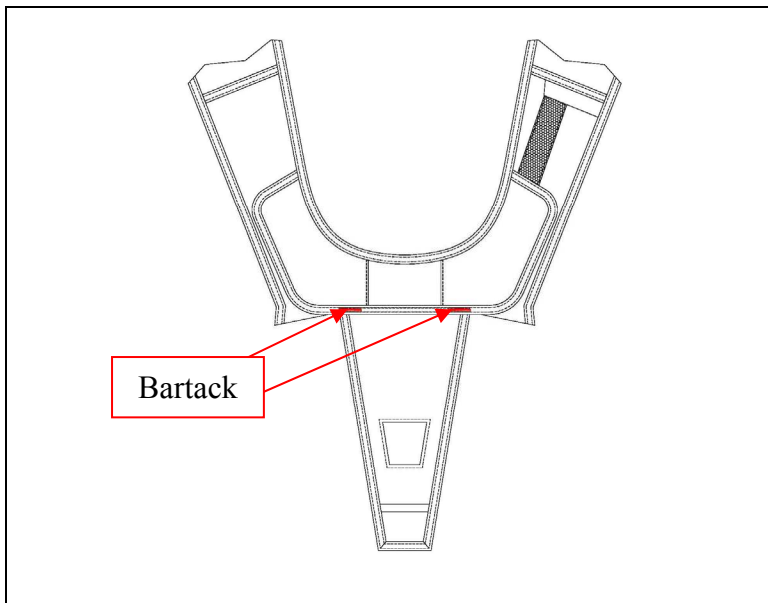

Carefully remove the two (2) indicated bartacks

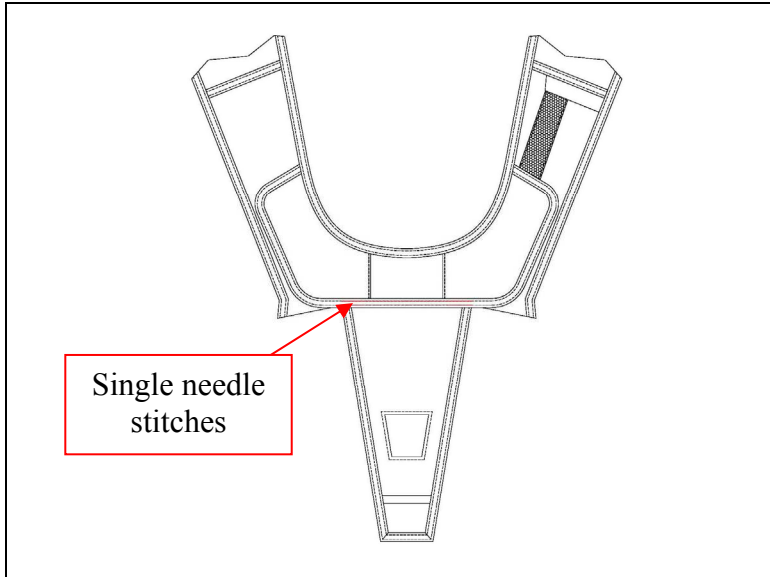

Next, carefully remove the two rows of single needle stitching attaching the RPC to the Yoke flap assembly.

The flap will now detach from the container.

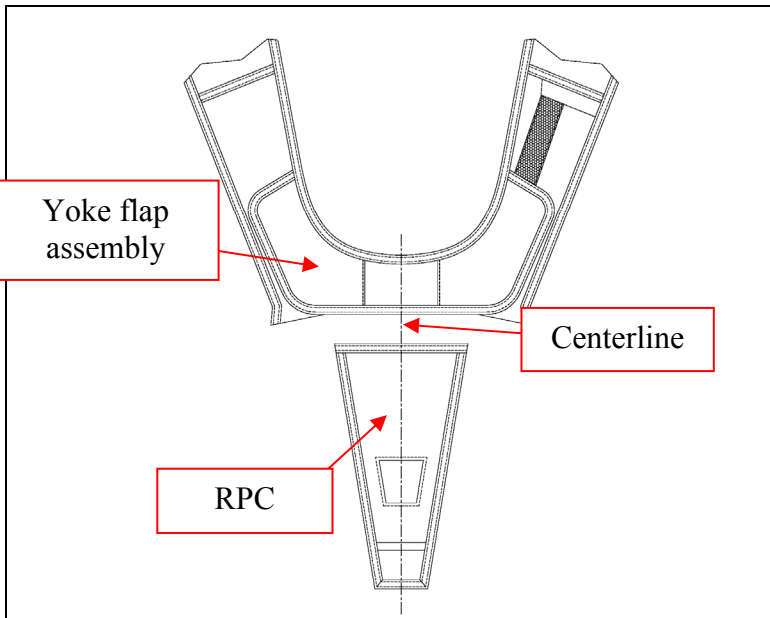

Mark the centerline on both the RPC and the yoke flap assembly before sewing to assist in proper alignment.

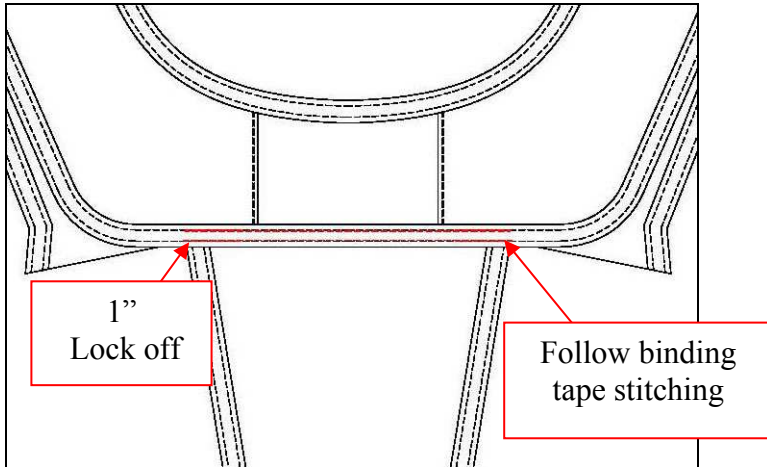

Installation of the replacement RPC is the reverse procedure.

Position the RPC so that the top bound edge is aligned with the binding tape of the Yoke flap.

Using E thread, sew two (2) stitch rows following the binding tape stitch rows making sure to triple lock 1" min at each end. The stitch rows should also step over the edge of the RPC binding underneath.

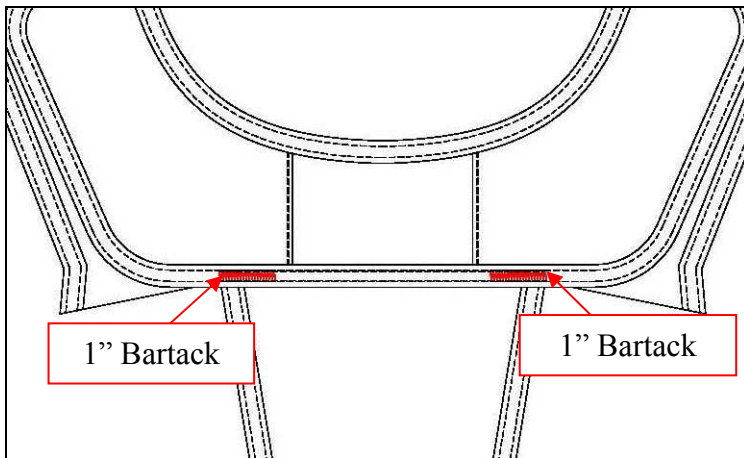

Next, install two (2) 1" bartacks at the indicated locations.

Center the bartacks between the stitch rows.

Optional – Bartacks can be substituted with double row of 304/single row of 308

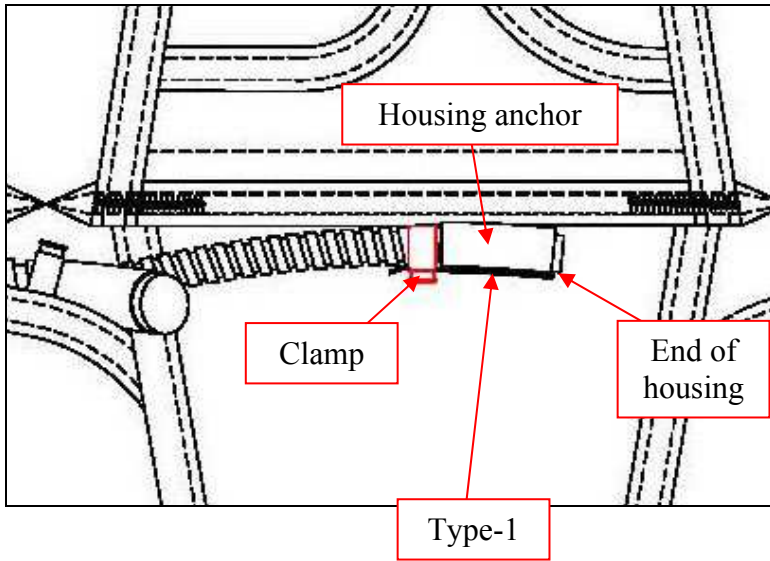

Reinstall the housing with the new clamp and Type-1 webbing.

Place the clamp on the housing first. Then pass the Type-1 webbing through the Housing loop anchor looping it back over to align the cut ends.

Move the clamp along the housing capturing the Type-1 until it is against the housing anchor.

The end of the housing should be even with the edge of the housing anchor.

Secure the clamp using the clamping tool or pliers making sure the ear of the clamp is facing downward and not sticking out.

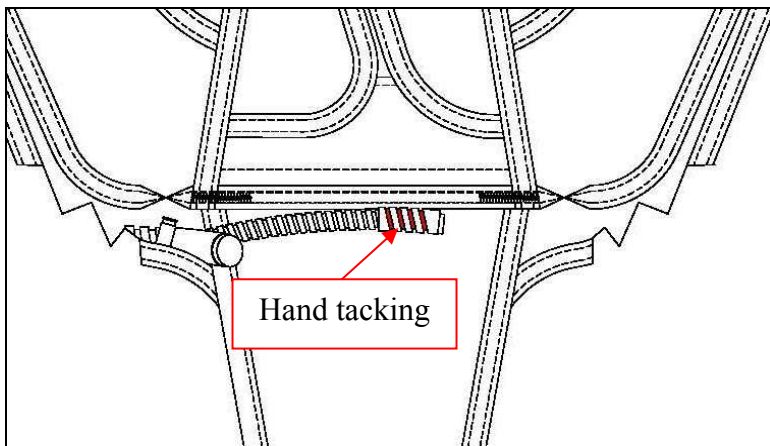

Optional – secure the housing into the housing loop anchor using wax hand tack thread. There should be four (4) turns around the housing as shown.

This completes the installation of the replacement Reserve Pin Cover