

WINX



Canopy User Manual

Edition 1 – April 2016

Contents

NOTE TO THE CUSTOMER	3
DISCLAIMER.....	4
HOW TO USE THIS MANUAL.....	5
READ BEFORE ASSEMBLY OR USE	5
INTRODUCING ATAIR.....	6
INTRODUCING THE WINX.....	7
RECOMMENDED CANOPY SIZING & WING LOADING	8
ASSEMBLING YOUR WINX CANOPY.....	10
BEFORE YOU PACK	15
PACKING YOUR WINX CANOPY	18
RECOMMENDED EXERCISES FOR FIRST FLIGHT.....	33
INSPECTING AND MAINTAINING YOUR EQUIPMENT	36

Dear valued customer,

We would like to thank you for the purchase of the Atair WinX canopy. We're confident you'll be pleased with it in every way and that you will enjoy how it opens, flies and lands.

We are kindly asking you and/or your rigger to carefully inspect your new canopy, in order to completely familiarise with it, and check it for possible imperfections. We are sure that Atair quality of workmanship is second to none, but should you find anything that doesn't look right, or if you have any questions, please don't hesitate to contact us or the nearest dealer.

Thank you again for choosing the Atair canopy. With a proper care it should last for many years and hundreds of jumps.

Blue Skies!

Andrej Krajnc & the Atair Canopies Team

Contact address:

Atair Aerodynamics d.o.o
Partizanska cesta 9a,
4220 Skofja Loka
SLOVENIA
Phone: + 386 451 265 65

E-mail:

andrej@basetroll.com

Web page:

<http://www.basetroll.com/>

DISCLAIMER

The following information must be read and understood before any use of this equipment.

The user understands the risks of skydiving and accepts that:

- Skydiving may cause serious injuries or even death. Some of these deaths and injuries can be attributed to equipment malfunctions. Skydiving equipment can fail to operate as intended, even when properly used and maintained.
- Failure to activate main or reserve parachute (or to follow emergency procedures) at a safe altitude, and/or equipment failures can result in severe injury or death.

It is the user's responsibility to:

- Conduct proper training before any use of this parachute and skydiving equipment in general.
- Read and understand all provisions of this manual, and limitations of all skydiving equipment he or she is using.
- Check all skydiving equipment and replace any defective or worn component prior to use.
- Review emergency procedures before each use of this parachute and all skydiving equipment.
- Do not exceed equipment limitations - check equipment warning labels.
- Comply with all training and safety requirements and recommendations for the specific equipment in use.

Because of the unavoidable dangers involved in the use of all skydiving equipment, Atair (including, but not limited to owners, employees and associates) provides no warranties of any kind, expressed or implied. This parachute is sold as is, with all possible defects and/or imperfections, and without any warranty for any purpose. By using this parachute or allowing it to be used by others, owner/buyer waives any liability of Atair for injuries, deaths or damages from such a use. Any promises or representations inconsistent with, or in addition, to this statement of warranty are not authorized by Atair and shall be not binding.

WARNING: SKYDIVING IS A HIGH-RISK ACTIVITY, WHICH MAY CAUSE SERIOUS INJURY OR DEATH! PLEASE READ THIS MANUAL BEFORE JUMPING YOUR WINX FOR THE FIRST TIME, REGARDLESS OF YOUR SKYDIVING EXPERIENCE OR NUMBER OF JUMPS.

HOW TO USE THIS MANUAL

We know that you are excited about receiving your new canopy, but please take time to read this manual thoroughly before the first jump, regardless of your experience level.

You will learn:

- The great new features of your **WinX** canopy.
- How to assemble, pack and safely use your **WinX** canopy.
- How to get the most out of your **WinX** canopy.
- How to take care of your **WinX** canopy.

NOTE: This manual is not an instruction course on how to make a parachute jump, nor does it contain any regulations that govern the sport parachuting and related activities.

READ BEFORE ASSEMBLY OR USE

Since parachutes are manufactured and inspected by people, there is always a possibility that this parachute contains imperfections or defects as a result of human error during production. Therefore, the entire parachute system – main and reserve canopies, harness & container, and other components – must be thoroughly inspected before the first use, and regularly checked throughout their lifetime.

Parachutes deteriorate over time for number of reasons. Even the regular use, packing, deployment, flying and landing will cause wear. Exposure to sunlight, heat and different chemical agents may cause the damage to the parachute. Some damages are easy to see, but some are more difficult to detect.

To help minimize the risk of parachute failure and possible serious injury or death, the entire parachute system should be thoroughly inspected at least once every 120 days or 50 jumps, whichever comes first. It should be inspected immediately after unusually hard opening, exposure to chemicals or excessive heat, or whenever any kind of damage is suspected.

Remember that some chemicals will continue to degrade the parachute long after their initial exposure. Regular and thorough inspections are necessary to insure structural integrity, reliability, and flight characteristics of the system are maintained.

In order to get the most of your skydiving equipment, use it and maintain it according to this manual, and keep track of use and maintenance history of your parachute system throughout of its lifetime.

INTRODUCING ATAIR

The Atair Company is made up of a family and friends who all share common passion for flying. Our passion helped us to develop number of great products which are enjoyed by thousands of people all over the world.

Our main focus is on BASE and skydiving canopies, but we are also active in all forms of human flight, including paragliding, hang gliding, speed flying and wingsuit flying. Atair is the most innovative company in the BASE jumping sector, world leader with products like **Troll** - one of the most popular BASE canopy in the world; **Trango** - lightweight canopy optimized for alpine use; **OSP** - for low altitude jumping; and **Peak** - ultra lightweight BASE canopy. Atair has also developed a very popular range of skydiving canopies like 9-cell **Impulse**, **Cobalt**, and **Radical**, 7-cell **Dragon**, and now the newest 7-cell canopy, the **WinX**. In the past, many of the Atair canopies were sold worldwide under different names through private labelling.

In parallel with the production of some of the world's finest parachutes we are also conducting research projects for both civilian and military customers. High quality of our products is comes from the excellent, skilled production team, most of them being with Atair since it was founded in 1992.

History

Atair was founded in 1992 by Stane Krajnc and his wife Magdalena. Over the last 25 years Atair has developed a range of skydiving and BASE parachutes and manufactured thousands of parachutes that have been sold all over the world.

Stane has been passing his knowledge and experience onto his son Andrej for years, who started paragliding at the age of 9, skydiving at the age 17 and BASE jumping a year later. Andrej graduated at the Faculty of Mechanical Engineering in Skofja Loka, Slovenia, specialising in the development and construction of BASE jump canopies. Stane and Andrej have been together in the business of parachute design and manufacturing for so many years, and Stane decided that it is time to leave the business to the young, talented and the innovative, and in 2009 Andrej Krajnc has been appointed as a new chief executive of the Atair Company.

Product development

In Atair we are constantly looking for new technologies, ideas and solutions in order to improve our products. Recent developments include a state of the art software upgrade to aid our design process and joint development of a new parachute fabric.

In Atair, everyone's ideas are welcome. The real talent and innovation comes from exploring those ideas, selecting the most promising ones and refining them into a hi-performance product. In that respect, Atair, Phoenix Fly, and Adrenalinbase all deserve accolades for their efforts.

We, the manufacturers, are striving to make our sport safer by advancing the technology that protects our lives.

INTRODUCING THE WINX



WinX - 9-cell performance in 7-cell canopy!

WinX - the latest addition to the Atair canopy range is designed for skydivers who need a canopy that has soft, consistent and reliable on-heading openings for wingsuit flying, but also enjoys more aggressive, high performance canopy rides.

WinX is a 7-cell zero-P semi-elliptical canopy, built on the quality foundations built by our earlier products: Radical, a 9-cell elliptical, and Dragon, a tapered 7-cell. The result is a 7-cell canopy that flies like a 9-cell elliptical.

WinX is extremely fun to fly at high wing loadings, being very responsive to toggle input, but at the same time rock stable in straight flight and turns. At light to moderate wing loadings, it's a great transitional canopy for novice or medium experience skydivers. The great glide performance will bring you home even if the spot was way off, and plenty of lift during the flare enables great, easy landings from a straight in approach.

If you like to swoop, the WinX will be more than happy to oblige. With a low pull force on the front risers, moderate recovery arc and a long, powerful flare, it's guaranteed to make you smile.

WinX was designed using specialist design software, used to analyse low speed airfoils and wings. With the use of advanced airfoil shaping techniques, it's possible to transfer a 3D design in to a 2D cut of canopy fabric panels. This results in a parachute that maintains its designed airfoil shape throughout the whole wingspan during flight. These techniques also give a thinner profile, which has resulted in a reduced packing volume.

As with all of our canopies, our class-leading manufacturing standards, and high grade zero porosity fabric guarantee a parachute that will maintain its superb performance for hundreds of jumps.

NOTE: WINX IS NOT A BASE CANOPY! IT IS FOR SKYDIVING USE ONLY!

RECOMMENDED CANOPY SIZING & WING LOADING

WinX size and data table

MODEL	AREA		MAXIMUM SUSPENDED WEIGHT						SPAN		CHORD		ASPECT RATIO
			NOVICE		INTERMEDIATE		EXPERT						
	m ²	sqft	kg	lbs	kg	lbs	kg	lbs	m	ft	m	ft	
WINX 105	9,20	99	/	/	54	120	76	170	4,40	14,40	2,2/2,0	7,20/6,55	2,07
WINX 120	10,60	114	/	/	62	140	88	195	4,70	15,40	2,3/2,1	7,55/6,85	2,07
WINX 135	12,00	129	58	129	70	155	99	220	5,00	16,40	2,5/2,3	8,20/7,55	2,07
WINX 150	13,40	144	65	145	80	175	110	245	5,30	17,40	2,6/2,4	8,50/7,85	2,07
WINX 170	15,15	163	73	162	90	200	117	260	5,60	18,35	2,8/2,5	9,20/8,20	2,07
WINX 190	16,95	182	82	182	100	220	120	265	5,90	19,35	2,9/2,7	9,50/8,85	2,07
WINX 210	18,85	203	92	205	110	245	120	265	6,20	20,35	3,1/2,8	10,15/9,20	2,07

Selecting the canopy of the proper size

For your safety it is important that you select your canopy according to your skill level and total suspended weight. You can choose your canopy between seven different sizes, with the area of 105 up to 210 sqft. Bear in mind that, as suspended weight increases, your forward speed and decent rate will also increase, canopy will become more responsive to toggle inputs, losing more altitude in sharp turns and stalls. Because of this basic aerodynamic principle, it is not safe to suspend too much weight under any particular canopy. Safe and comfortable landings will be difficult to obtain, even for experienced jumpers under ideal conditions. Less experienced jumpers will have an even harder time, with increased chance for an injury.

Determining actual wing loading for the canopy you intend to jump or buy is a good start in matching yourself with a particular canopy.

Wing loading is easily calculated by dividing the total suspended weight (in pounds) by the surface area of the canopy (in square feet). Canopy surface area can be found on the data label, located on the centre cell top surface near the trailing edge. Total suspended weight is the weight of the jumper plus all his gear and clothing, including the main parachute itself.

A typical skydiving rig weighs between 20 to 30 lb. For example, a skydiver who weighs 165 lb with his jumpsuit on, and who jumps a packed rig that weighs 25 lb, would have a total suspended weight of **190 lb**. If skydiver is using a **210** sq ft canopy, wing loading is:

$$190 / 210 = 0.9 \text{ lbs/sqft}$$

By using the above example, calculate the wing loading for the canopy you intend to jump.

If wing loading is below 1.0 the parachute will be relatively docile and easy to land. It will also have

reduced penetration into the wind.

If wing loading is between 1.0 and 1.2 the canopy will turn fast and have high forward speed. It will also require higher skill level to land well in all weather conditions or at high altitudes. Be sure your skill level is up to the demands of this wing loading.

If the wing loading is between 1.2 and 1.7 you are exposing yourself to a high risk situation. Turn rates, forward speed and rate of descent will be very high. Control range may be very short with stalls happening very abruptly with a little or no warning. Normal landing techniques may be sufficient for controlled landings. Extra speed on approach to landing may be required in order to get enough flare to stop your rate of descent. Therefore, a double front riser approach, or front riser turn may be required for landing, both being high risk manoeuvres.

If the wing loading exceeds 1.7 we do not recommend anyone to jump such a canopy.

It also is useful to compare the wing loading of a canopy you intend to jump with the values of wing loading of parachutes you've been jumping before. If the difference is large, you should expect the new canopy to perform very differently than the ones you've jumped before.

It is highly recommended to use first few jumps on the new canopy as introductory jumps, and open high in order to practice all manoeuvres and flight regimes at altitude, and familiarize yourself with your new canopy. Introductory jumps will help you discover how your canopy flies, turns and stalls, and how and why your canopy may respond violently. You will learn to recognize what your canopy is "telling you", and develop a feel if a canopy is about to do something violent. You have to have adequate experience level and be familiar with all canopy flight regimes in order fly it safely.

ASSEMBLING YOUR WINX CANOPY

Do not assemble your canopy yourself unless you have the required knowledge and skill. If not, please have this done by a qualified rigger. This operation has to be performed by a qualified person, and in accordance with the appropriate regulations of respective country.

Before assembly, the canopy must be inspected and checked. By assembling, packing and jumping your canopy, you accept that your canopy and its components are airworthy.

Line assembly

Each link must have four lines attached. Bear in mind that lines have to be placed on connecting links in proper order, and have to run straight from the connecting link to the canopy. Check each link for proper assembly. Follow each of the two steering lines (cascade from single line at the riser into four lines attached to the canopy trailing edge) if they run straight from the tail to the riser, before attaching toggles.

Once you have properly positioned the lines on the connecting links, inspect them. Attach each connecting link to the corresponding riser.

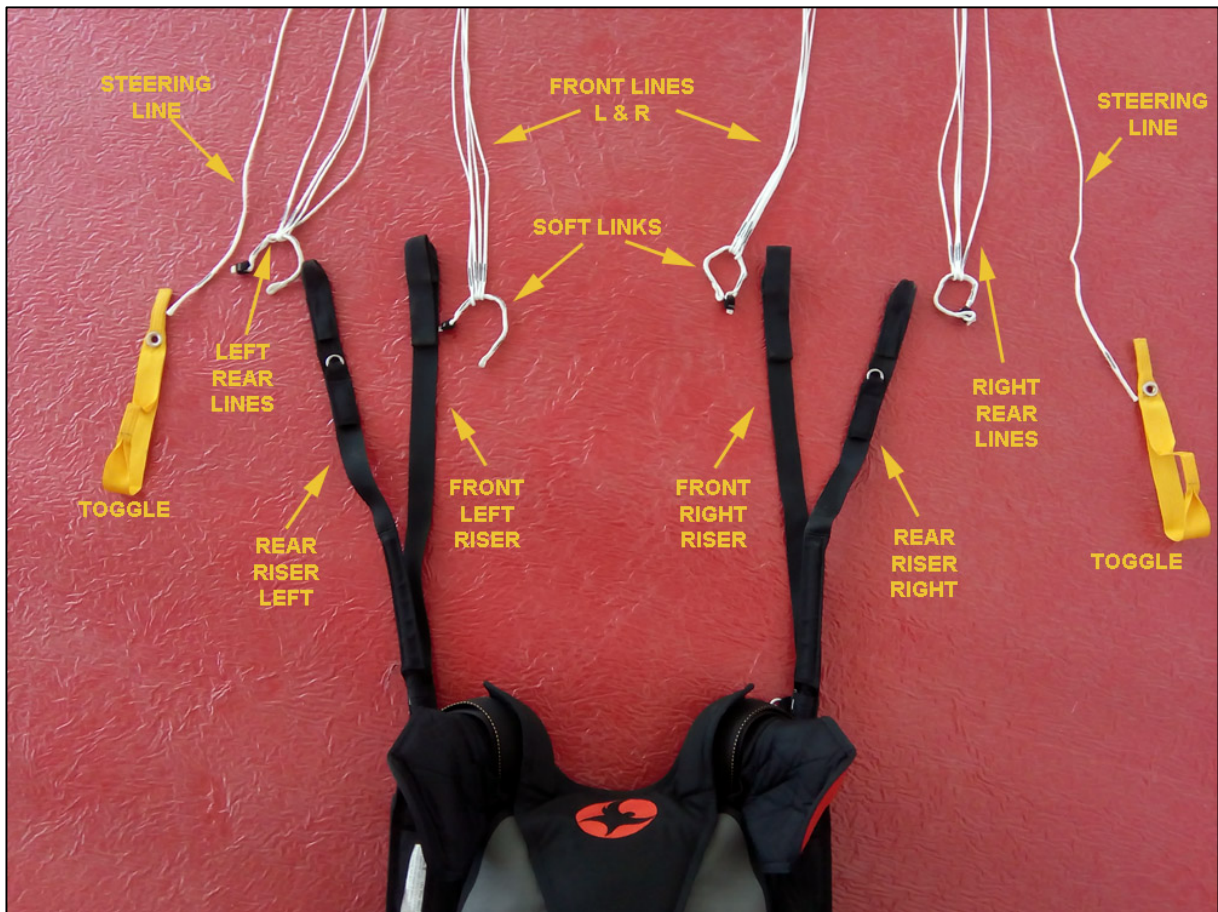

If you are using soft connection links, some installation guides can be found here:

http://www.performancedesigns.com/docs/SlinkInstructions_1.pdf

<http://www.flyaerodyne.com/download/SoftLinkManual.pdf>

Before installation, please refer to appropriate manufacturer's soft link installation guide.

Lines attached to the riser using the soft links are shown here:

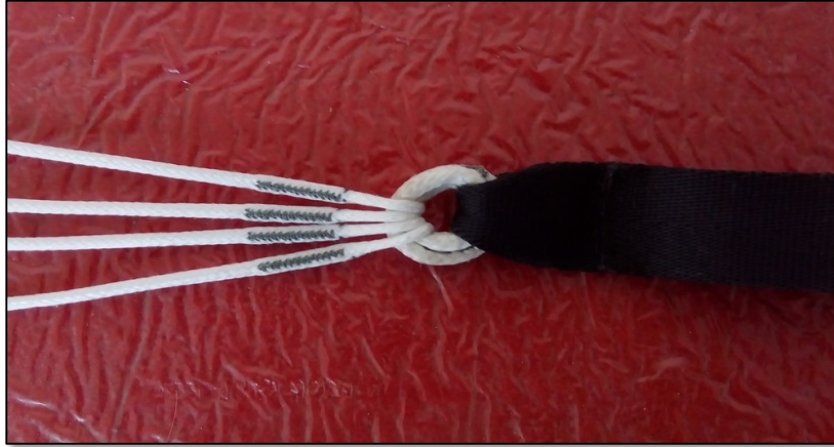

If you are using steel (French) links, finger-tighten the nut as much as possible, and then apply $\frac{1}{4}$ up to $\frac{1}{2}$ turn with a wrench. Do not over tighten as this can damage the thread or crack the link nut, causing the link to fail. Pull the slider bumpers (covers) over the links to protect the lines.



Toggle assembly

Once you have assembled and secured lines to the corresponding riser it is time to assemble the steering lines and toggles. Starting from the trailing edge of the canopy take each steering line and follow it down to the riser, ensuring it is clear and not interfering with the other lines. Make sure that steering lines goes through corresponding slider grommet. Route the left steering line through the guide ring (or rings) on the rear left riser. Then repeat the process with the right steering line/right riser.

Pass the steering line through the guide ring on the riser.

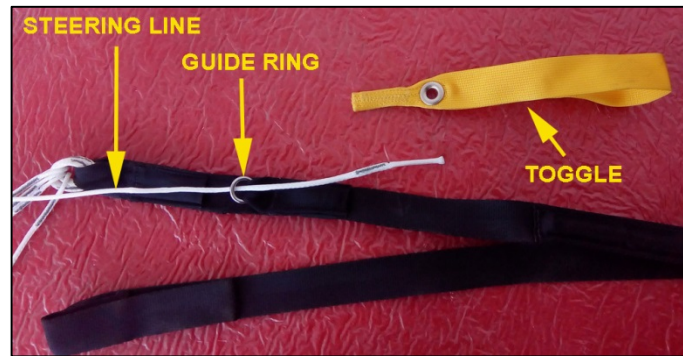

Pass the loop at the end of the steering line through the toggle's grommet.



Then thread the bottom end of the toggle through the steering line loop, and pull slack control line back through the grommet.

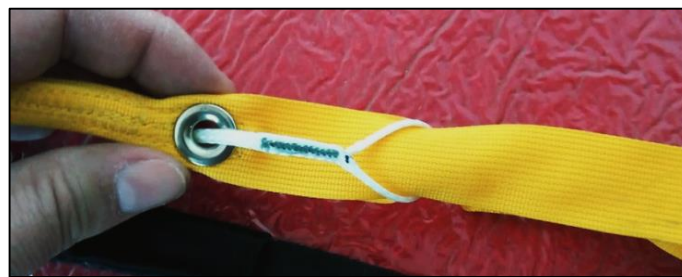

The assembled toggle should look like this.



Checking the lines on the assembled canopy

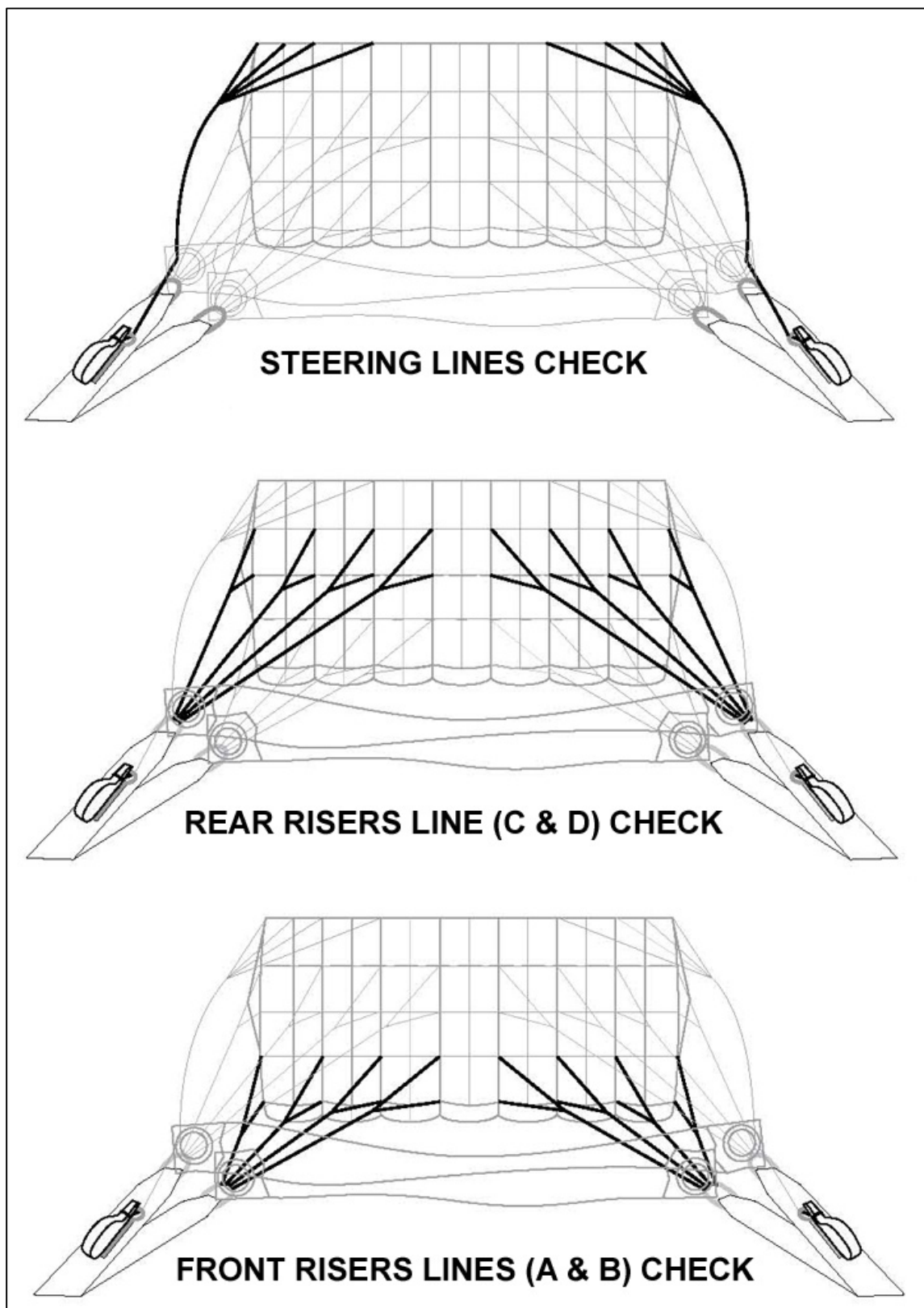

Proper look of the front line set on the inflated canopy (only right side shown)

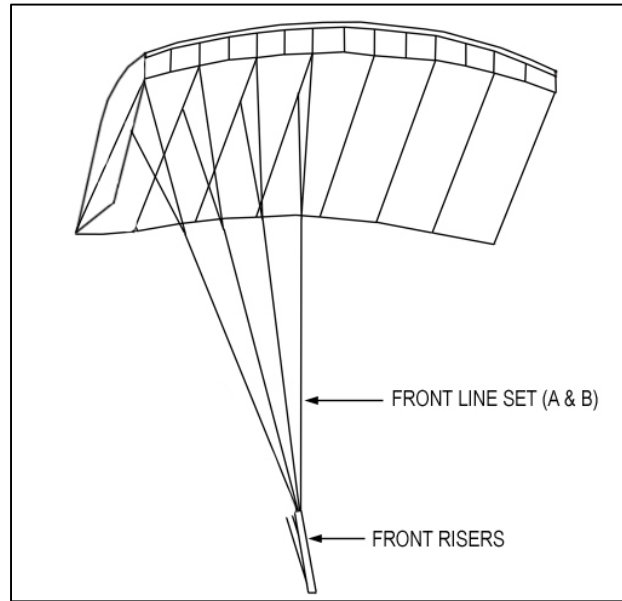

Proper look of the rear line set and steering line on the inflated canopy (only left rear line set and right steering line shown)

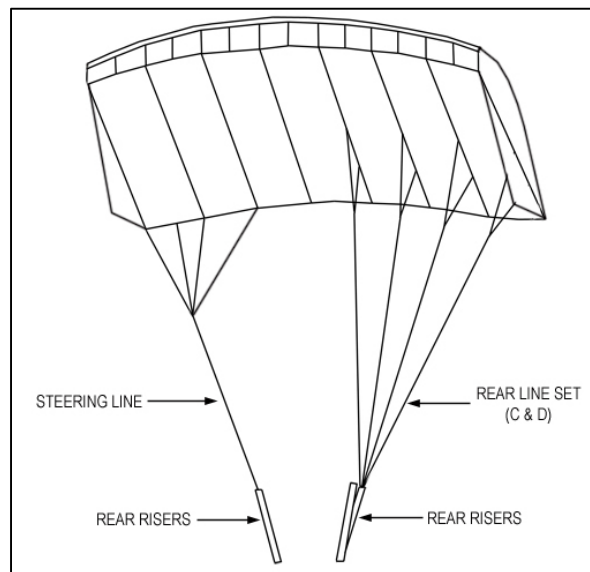

Once the canopy is attached, check one more time that the connecting links are secured. When assembling is complete, we are recommending checking the canopy installation one more time. It can be done on the floor and/or by suspending or inflating the canopy for a sufficient time to check lines for proper order and continuity, and check other canopy components.

BEFORE YOU PACK

Before you pack your canopy for the first time, please read this manual thoroughly. If there are any parts you don't understand, please contact us or a qualified rigger to help you with packing.

Ensure that you have correctly assembled the canopy to the risers. Be certain to secure the rig so it does not move during the packing process. Make sure that the risers and lines are even and remain even at all times.

Modern ram-air canopies are very reliable. If a ram-air canopy is correctly assembled and lines are not tangled before packing, it will usually inflate and open as required, even if folded in some quite unusual manner. In other words, it is difficult to pack a ram-air canopy in such a way that it malfunctions.

We're not saying other packing methods won't work with your canopy. But the method shown here will provide for the most reliable and consistent openings.

Before you begin

Picking proper packing spot is important. Since sunlight damages the nylon fabric your canopy (more precisely, UV radiation in sunlight spectrum), packing the canopy indoor or in shade is the most preferable option. Sometimes, packing outside in the sunlight is unavoidable, so try to reduce canopy exposure to direct sunlight as much as possible. Cover it with a packing mat or jumpsuit while you debrief a jump or debrief your student.

Packing on concrete and asphalt should also be avoided because this will wear the fabric, lines and fittings of your parachute system. Packing on a tarpaulin or a dry short grass is the best. Packing behind a building or van will make packing easier because it blocks the wind.

Pack according to your country's regulations (e.g. by yourself if you intend to jump your canopy, or by a certified rigger, or by the other person that will be jumping the canopy)

Packing assistance

When you are learning to pack, read this manual first, but also do not hesitate to ask a rigger, your instructor or experienced skydiver for assistance or help. They will show you tips & tricks that will make the packing faster and easier. Be sure they refer to this manual, however, as they might not know our packing method.

Packing canopies made of zero porosity (ZP) fabric

Canopies made from ZP can be packed just like any other similar canopy. If you prefer to flat pack, and have been getting good results with a similar canopy, this method should work with your new canopy. Many different packing methods are currently being used. We recommend the pro-pack described in detail in this manual. This packing method results in consistent, soft, on-heading openings, with a minimized risk of hard or off heading openings. Others may not work as well. If you try a different pack method, you do so at your own risk. If you use a side or book pack, start at the tail and work forward in order to squeeze the air out of the canopy.

Packing a canopy made of ZP is a skill that has to be mastered. At first, it will be more difficult to pack in comparison to the canopies made of conventional f-111 fabric. However, with practice it will become just as easy. You can make the pack job considerably easier by getting a bag that is slightly larger than your main container (you may consult the container manufacturer for that). It is easier to squeeze a small amount of the air out once the canopy is in the bag, and then place bag into container.

The key to make the packing easy is to pack quickly and accurately. Each fold or roll must be done

quickly and correctly the first time. This will only come with practice. Packing does not hurt the canopy, so please practice until you are good at getting a neatly folded canopy into the bag before you start jumping the canopy.

The fabric has a memory and always tries to open back up. Once you start, you must continue until the canopy is in the bag and the lines are secure in locking stows. You can't waste time at any point during packing because this gives the canopy time to expand back, ending in a big mess, and you will have to start over.

After the flaking of the canopy is done, you should roll the tail as tight as possible. Slowly lay down on the canopy while still holding it with your hands. Be careful not to let the tail unroll while laying the canopy on the ground and squeezing the air out. If you kneel on the canopy facing the pilot chute attachment just below the warning label, it will be easier to control the canopy. The only place for the air to leak out is the stitching holes, so go slowly. If you go fast, the air will blow the pack job apart.

Inspection

You must inspect your parachute system every time you pack it. The inspection takes only a few moments and will help prevent malfunctions, damages and other problems. The inspection is best done when the rig and canopy are stretched out on the ground prior to packing. (The procedure outlined below is different than the thorough inspection that must be performed periodically and when the parachute is first assembled or if damage is suspected. The thorough procedure was presented earlier).

If you discover any worn or improperly rigged components, bring them to the attention of a certified rigger before jumping the system again.

During the inspection of the entire system, pay special attention to the items listed below. Any damaged or worn parts must be repaired or replaced before jumping the system again.

Start with the harness and container and work up to the canopy and pilot chute. Although the owner's manual that came with the rig contains specific inspection procedures, be sure to check the items listed below.

Reserve - it has to be in date and sealed. The ripcord pin(s) must be seated properly and not bent. The cable must move freely in its housing. The ripcord handle must be properly stowed in its pocket. If the rig is equipped with an automatic activation device, it must be installed and calibrated correctly.

Harness & container- inspect the entire harness for broken stitches and excessive wear.

Closing loop - must not be worn, broken closing loop can cause premature opening, which is a high risk situation.

Risers: Check the risers carefully for any damage or excessive wear. Check the 3-ring releases, be sure the white locking loop is not worn (it must only pass through the smallest ring). Be sure the release cables are inserted correctly in the white loops.

Check the **steering lines and toggles**. Look for damage; check if knots are tight and that the toggles are securely attached. Serious injury could result if an incorrectly attached toggle detaches from the steering line during flare – don't let it happen to you.

Check the **Velcro** for wear.

Check the **connecting links**. If you are using steel links, see if nuts are securely tightened and check them for cracks.

Slider - be sure the slider isn't twisted and that its grommets are free of scratches or burrs that can damage the suspension lines and steering lines.

Suspension and steering lines - inspect these lines for wear. Be sure they are "continuous" (not tangled). Each line must go straight from its link to the canopy without wrapping around other lines. The risers should not be twisted either.

A tip: Pick up your canopy neatly after each landing, and lay it down neatly when you get to the packing area. Doing this will enable your packing go faster because the lines will remain untangled (lines do not pass through each other, as can happen if you walk through the lines after landing).

If you find any incorrectly routed or twisted lines, it is usually better to leave the risers attached to the harness, and work complete rig through the lines when untangling them (unless the risers were attached incorrectly to start with). Disconnecting the risers usually makes it more difficult to straighten things out.

Canopy -be sure the canopy is not installed backwards. Inspect it for tears, especially at the line and pilot chute attachment points. (You should periodically look inside the centre cell to inspect the bridle attachment point.)

Deployment bag, bridle and pilot chute -refer to the owner's manual. Tears or failing seams on the pilot chute are especially hazardous. So is a worn or too short bridle.

After packing your canopy for a few times, you'll be able to do inspection simultaneously with the packing, you'll inspect it as you pack it.

PACKING YOUR WINX CANOPY

This is a recommended packing procedure. Any packing system or method that is in accordance with general packing principles described in this manual is acceptable. All skydivers are individually responsible for packing their canopy.

After assembling and inspecting the canopy and harness/container, lay the canopy out on a smooth, clean surface. Secure the rig in place (by tying it to a fixed object or by using a packing weight). Straighten the canopy and lines.



Stretch the slider as shown below. Slider is collapsible in order to ensure full flight performance, avoid disturbing noise during flight and to prevent wear of the lines at the riser attachment points. **YOU MUST REMEMBER TO STRETCH THE SLIDER DURING PACKING PROCESS! FAILURE TO DO SO COULD RESULT IN VERY HARD OPENING AND SERIOUS INJURIES OR EVEN DEATH.**

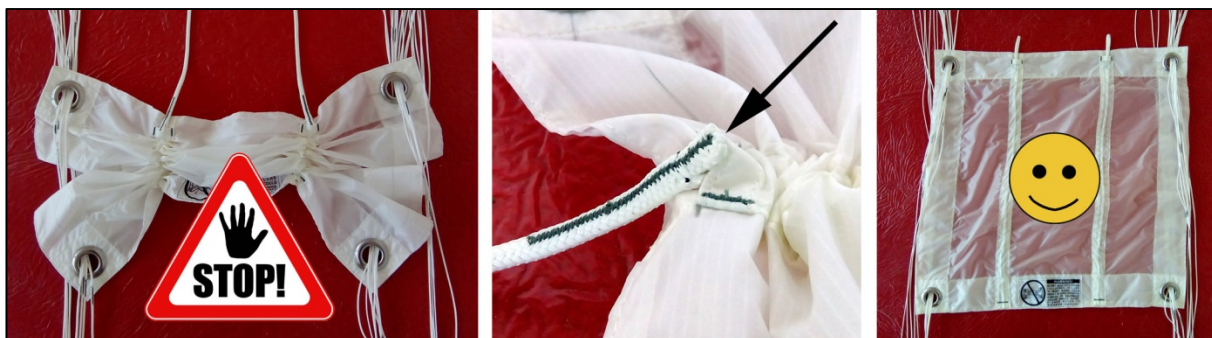

To set the brakes for both steering lines pull the steering line loop through the guide ring on the riser.

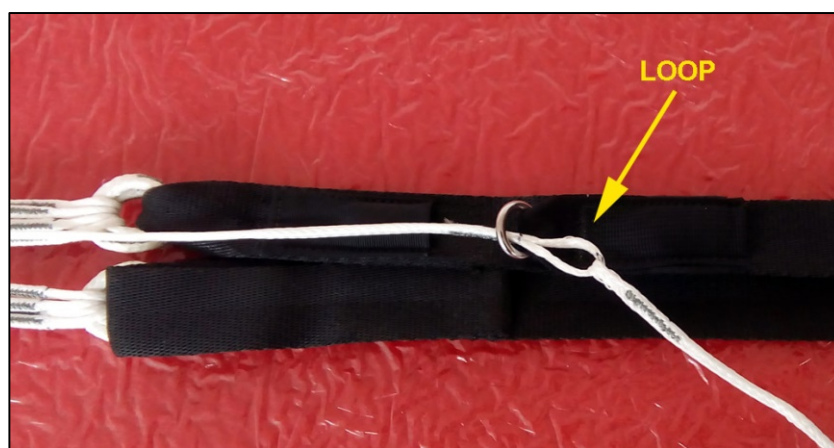

Insert the toggle through the steering line loop.

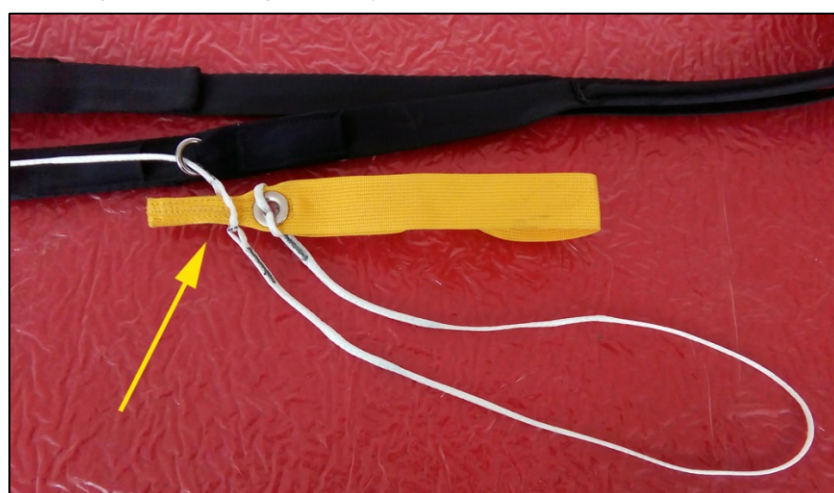

Secure the toggle onto the riser.



Stow the slack brake line on the riser.



Brake set and secured for packing/jump.



LAYING THE CANOPY OUT

Make sure you have fully stretched the slider and that the slider retraction lines are pulled firmly against the trailing edge so that they cannot catch on the suspension lines during opening sequence.



Perform a line check, to see that the line sets are straight, without twists, that brake lines are straight and on the top of other lines, check the continuity above and below the slider.



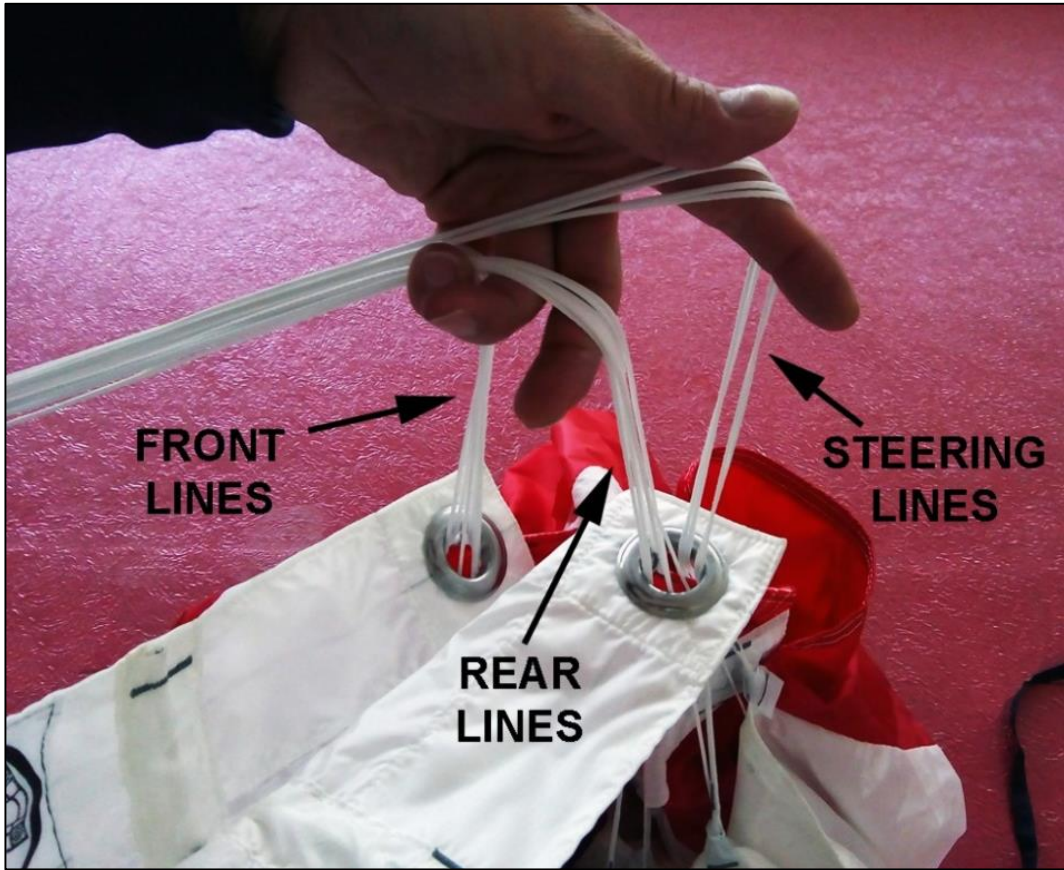

Make sure that lines are even, by aligning steering lines knots, in order to have symmetrical pack job.

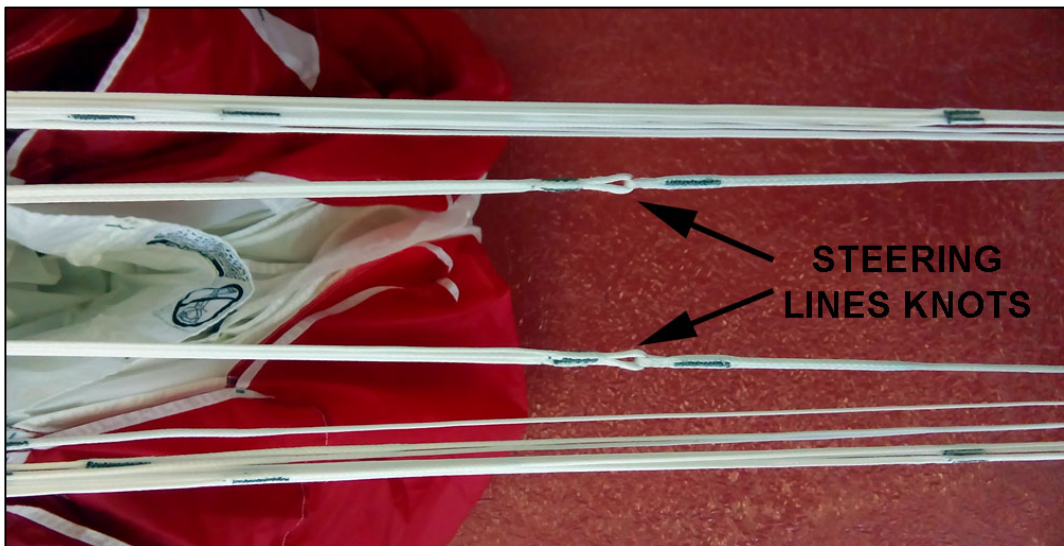

Take the canopy in one hand.



Clear the nose of the canopy by flaking the cells at the canopy leading edge (nose). Pull out and count the cells. Align the front edge of the slider with the flaked leading edges



Holding the cell inlets firmly, vigorously shake the canopy in order to stretch it and align the canopy and lines.



Then, on one side of the canopy, put your hand inside the canopy and make a fold to separate line groups A & B.

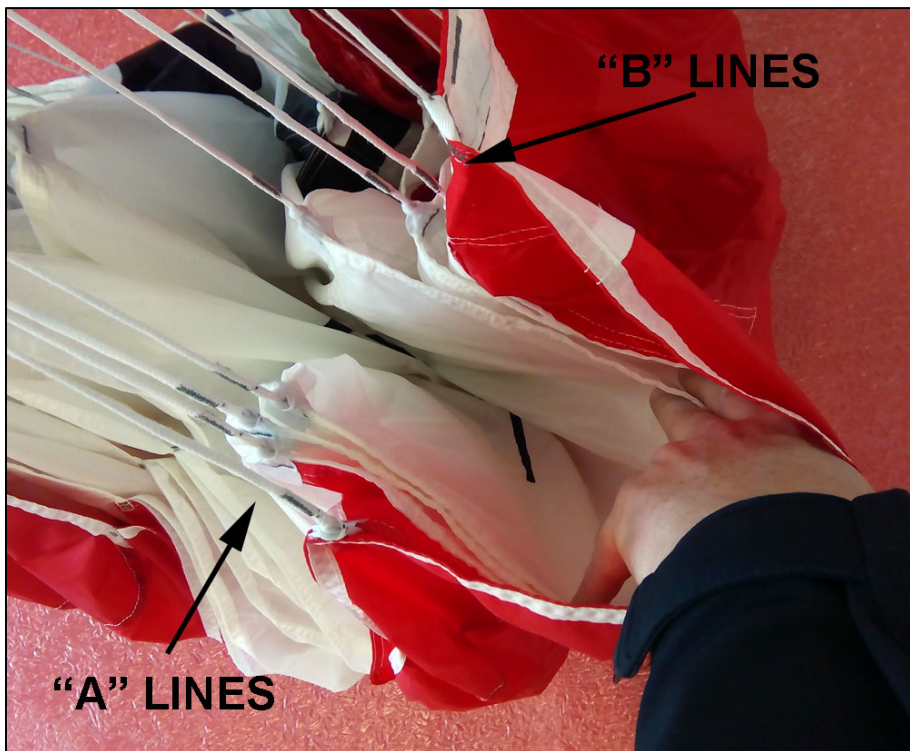

Fold and separate line groups B to C in the same way.

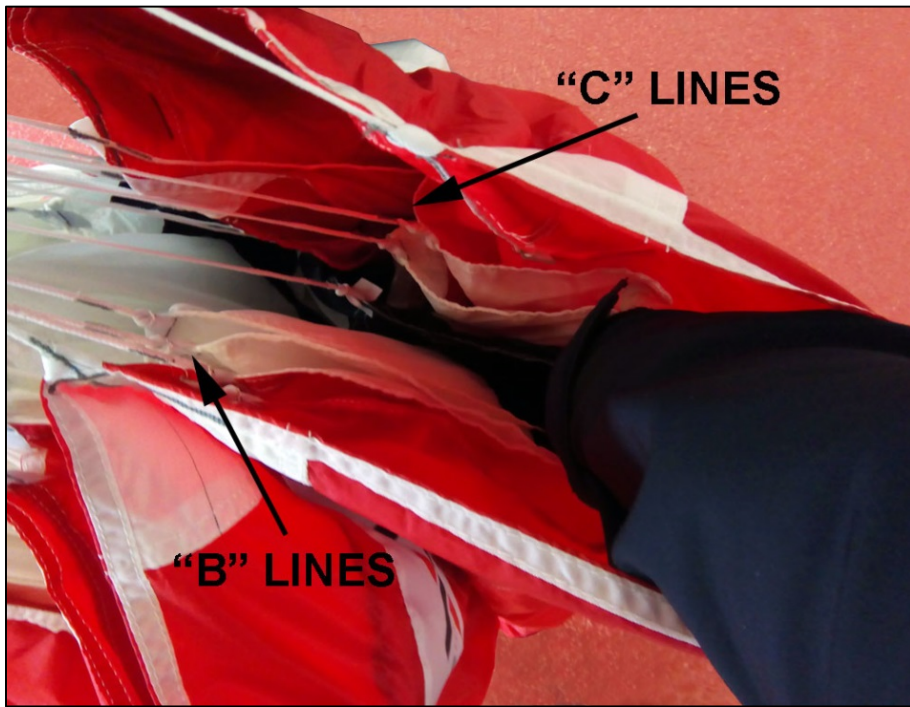

Fold and separate line groups C to D in the same way.

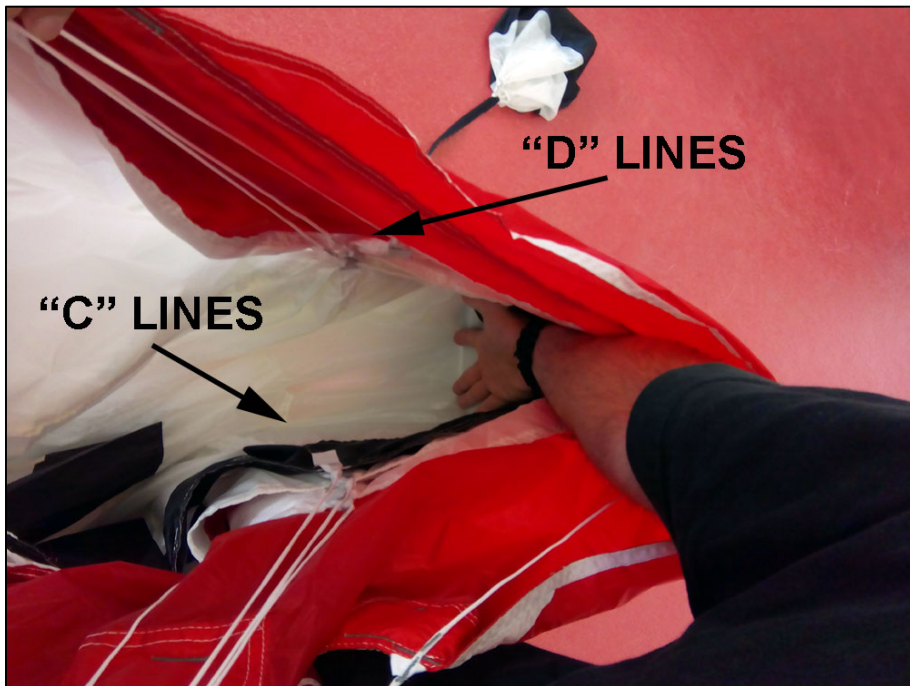

Flake the stabilizer outwards.



Flake the tail outwards.



Repeat the procedure on the other side of the canopy, until both sides are folded and flaked.



This is a front view of the folded and flaked canopy. While keeping the nose pointed towards yourself, check that the slider is properly positioned and spread between the 4 line groups (front &, back, right & left) and that the slider grommets are pushed all the way up against the slider stops.



This is a rear view of the properly folded and flaked canopy.



Pick up the centre cell by its trailing edge (identified by small red or black tape) and lay it on top of the lines just below the slider.



Hold firmly, and make sure that the slider stays in place, pushed up against the slider stops. Also make sure that the steering lines remain in the centre and in the back.



Take both sides of the canopy tail and bring them around towards the front (nose) of the canopy. It is very important to make sure that no (steering) lines pass in front of the leading edge (nose), as this may cause a line-over malfunction.



Join the two sides of the tail in front of the canopy leading edge (nose), and firmly and tightly roll the tail, making sure not to catch the leading edge in to the roll. Never lose the grip on the canopy lines and the slider.



Gently swing the canopy out and lay it on the floor as shown. Carefully push the air out of the canopy. Again, make sure that the slider stays in place against the slider stops. **WARNING: IF THE SLIDER IS NOT ALL THE WAY UP AGAINST THE SLIDER STOPS, THE POSSIBILITY OF A HARD OPENING IS SIGNIFICANTLY INCREASED.**



Roll the canopy into tight "sausage".



S-fold the canopy and then place it into deployment bag.





Close the D-bag and stow the lines.



When stowing the lines, we are recommending to leave between 50 - 60 cm (20" TO 24") of lines free at the end in order to prevent line twists during opening.

RECOMMENDED EXERCISES FOR FIRST FLIGHT

Even if you are familiar with ram-air parachutes, your new parachute may handle differently than parachutes you jumped before. Therefore, we recommend making few jumps in order to familiarize with your new parachute. Pick a day with favourable wind conditions and jump by yourself.

Open high and find out how the canopy flies. At first, try slow turns and fast turns from no brakes, quarter brakes, half brakes, three-quarter brakes and full brakes. Determine if the canopy can do stall (helicopter) turns, and if it does, under what conditions. Find out how the canopy recovers from various types of stalls.

Stall the canopy several times and see how this happens both from full flight and deep brakes. Turn the canopy by pulling on the front or rear risers rather than the toggles. Keep track of your location relative to your intended landing area as you exercise your canopy, so you won't drift too far away. Stop playing with the canopy under 300 m (1000 ft) above the ground.

Plan and execute a conservative landing approach into a large unobstructed landing area. Steer, flare and land the canopy as you were taught by your instructor when you were student skydiver. Since you might misjudge your early landings be prepared to perform a "Parachute Landing Fall" (PLF) rather than forcing a stand-up landing. Most jumpers underestimate how far they will travel over the ground during the landing flare. Make sure you have enough open space ahead of your intended touchdown point.

During the first few jumps try the following exercises:

- Gradual flare to locate the stall point
- Full flare to simulate landing
- Full stall and recovery by slow and equal brake release
- Flare from half brakes
- Flare from deep brakes
- Full toggle turns
- Half brake turns
- Deep brake turns (in deep brakes slowly release one toggle in order to turn)
- Rear riser turns
- Front riser turns
- Check length of steering line between the loop and toggle, are you getting a full flare?

Remember to pay attention to your altitude and position relative to the dropzone!

Flight Characteristics: This Atair canopy is not just a new canopy – you have just purchased a totally new product, full of new features, top class production quality and exceptional performance, making it incomparable to the classic ram-air parachutes. It only requires light toggle input to turn.

It is not necessary to pull a long way down on the toggles to obtain a quick rotation. You should learn to steer your canopy using smooth inputs.

Landing: Make sure that you are facing into wind, lined up with the landing area of 100 m (330 ft) in length as a minimum.

Keep your arms high so as to maintain full speed, and then execute your flare. The landing procedure is standard; however, if you vigorously pull the toggles, due to the excellent flare characteristics, canopy will go upwards until the airspeed is lost.

Pay attention to this, steer smoothly and, should you come upwards too much, keep the toggles at the same level till you touch down, and do not release brakes. Always remember that this canopy will continue flying until it completely loses airspeed and your complete weight is on your feet, so do not release toggles before canopy is at a complete stop.

ATTENTION: SHARP TURNS AT LOW ALTITUDES OR JUST BEFORE LANDING ARE EXTREMELY DANGEROUS AND CAN CAUSE SERIOUS INJURY OR DEATH!!!

High Performance Landings

At most dropzones there are some jumpers who like to do high performance landings (swoops, hook turns). These landings look impressive, travelling long distance few centimetres off the ground and then going up before landing. The problem is that these landings can be very dangerous for the jumper, other skydiver and people on the ground.

Many of these swoop landings are started by initiating a sharp turn at the low altitude. If timed incorrectly the jumper can hit the ground with high speed, resulting in very hard impact, hard enough to be fatal. Also, many jumpers have been hurt by colliding with other jumpers during the swoop.

To minimize the danger involved in skydiving you should avoid all turns close to the ground, and turns that are bringing you in close proximity to other jumpers in the air, or the ground. It is recommended that all jumpers limit their turns to only minor course corrections below 100 m (330 ft). If you insist on performing a swoop landing, make sure that you are in clear air space and have sufficient area to land. **DO NOT attempt a swoop landing if there are other jumpers in close proximity around you in the air, or there are people in the landing area.**

Do not try any swoop landings until you are very familiar with your canopy and the landing area. Even people who are very skilled occasionally manage to get hurt. You do not need more speed than full glide to do a proper landing during the learning period. Never try a swoop landing unless the weather conditions are favourable. As you become more familiar with your canopy, you may want to start using a faster approach for landing. If so, increase your speed in small increments over number of jumps. Most people get hurt by trying too much too soon. Try several practice approaches while at altitude, before trying it at landing. Do not attempt a high speed landing until you are sure you can deal with the initial high sink rate.

The best weather for practicing is a smooth, calm, low wind day. On such days, the canopy will be stable and will respond only to pilot control inputs. It is important to avoid the possibility of the canopy being influenced by changes in wind direction or speed.

The goal of the swoop landing is to skim your feet across the ground or to make the canopy go back up. There is a limited canopy control range to accomplish that. If you pull the toggle down just a little beyond what is necessary to skim across the ground the canopy may start to climb. However, just a little more toggle may cause the canopy to do a high speed stall. In other words, if you pull your toggle down any more than it is necessary you will pass right through the control range you want. The result of this could be dangerous. The exact position of this small area of control range of the canopy is different on almost every jump.

You must have a complete and thorough understanding of your canopy to know exactly what to do

for every approach. Remember that at the end of every swoop is the landing. If you get yourself in a position that you are several meters above the ground, and the canopy does not have enough air speed to fly, you will just drop from that altitude!

Once you have mastered the canopy, you may decide to try approaches at high air speeds. Remember, the faster you go, the harder you will hit, so be careful. There are three methods to gain extra airspeed on approach: pulling both front risers to swoop, front riser swoop, and toggle swoop.

Pulling down both front risers on a straight in approach is the best method for beginners, and the least dangerous one. Even a small pull on the front risers (less than 5 cm/ 2") will result in a significant increase in airspeed (increasing the flare power on almost any landing). The flare then begins with a smooth release of the front risers, and continues by smoothly pulling the toggles down as much as necessary. The altitude to begin the flare varies with each approach and how fast the flare is executed. It takes practice to determine these factors. When using front risers to gain extra speed, never let go of the toggles for any reason. Also, be sure not to use front risers in gusty or turbulent winds. Pulling on front risers in these conditions could cause your canopy to collapse!

Front riser swoops. This technique is more advanced, but also more dangerous. Forward speed increase during this manoeuvre is much more dramatic than with a straight front riser approach. Also, judging the required altitude is much more difficult. If you misjudge this type of approach, you could easily hurt yourself. If you choose practice this type of swoops, start with 45 deg turns, and then slowly increase the turn (to 90 deg, 120 deg, etc.), and ask for advice.

Toggle turn swoops are the most dangerous of the three options and offer no advantage in terms of performance. By making sharp toggle turn canopy will enter a steep bank, but at the same time it will lose airspeed. The only way to recover airspeed is to trade altitude for speed. And until you recover airspeed, you will not have any control of the canopy. If you make sharp toggle turn too low, you will not be able to recover canopy from the dive, and that can result in serious injury or death. We are recommending NOT TO TRY toggle turn swoops under any circumstances.

If you are interesting to learn more about canopy piloting, there is plenty of information available on the web, such as this very comprehensive BPA manual:

<http://www.bpa.org.uk/assets/Training/Canopy-handling/cpmanual.pdf>

INSPECTING AND MAINTAINING YOUR EQUIPMENT

Your canopy must be inspected thoroughly before it is assembled and jumped for the first time. After that, periodical inspections should be performed every 50 jumps or 120 days, whichever comes first. This procedure is more detailed than the regular check during packing.

You or your rigger should inspect your parachute system in a clean, well lit, unobstructed area that will allow you to lay and spread the canopy on the floor, or to suspend it from the ceiling.

The best way to inspect your canopy is to do it carefully and systematically. We are recommending starting from the top of the canopy and then working down towards risers. You should leave the canopy attached to the rig.

1. Bridle attachment - check to be sure the bridle is correctly attached to the canopy. Check the integrity of the canopy fabric and reinforcement tapes in the area where the bridle ring is attached,
2. Top surface – lay canopy down on its bottom surface and inspect the top surface. Look for rips, stains, or failed seams. Check the fabric strength by grabbing a handful of fabric in each hand and trying to tear the canopy with a moderate tug,,
3. Bottom surface - turn the canopy over and spread it out to inspect the bottom surface. Check for rips, stains, and failed seams. Check the fabric strength (see #2 above). Check the line attachment points,
4. Inspect each rib - from the leading edge to the tail by looking inside each cell. Pay extra attention to the line and bridle attachment points,
5. Lay the canopy neatly on one side, stacking each rib on top of the others. Check that all the lines in each line group are the same length and that the trim differential between each line group is correct for this canopy. Check the condition of the stabilizers and slider stops,
6. Suspension lines - check the full length of each line for damage and wear. Look for fraying at all cascades (the Y- shaped junction of two lines) and where each line attaches to the connecting link,
7. Slider - be sure the fabric isn't torn, that the grommets are undamaged and have no sharp edges, and that they are securely attached to the slider,
8. Risers – for steel connection links, check if link nuts are tightened and the slider stops are properly positioned. For soft links, check them for wear and tear, and proper installation. Check steering lines for wear and tear. Check the three ring system for possible damage and function,
9. Follow the instructions in the rig manufacturer's owner's manual to inspect other parts and assemblies of your parachute system.

This is recommended procedure for inspection of your main canopy. For inspection of the rig and other components and assemblies, please refer to the respective owner's manual.

Cleaning your canopy

Standard Fabric - avoid washing or cleaning your canopy if possible. Cleaning the material will increase the porosity, and consequently reduce performance. Clean only the areas that are contaminated with a substance that could cause damage or degradation of the fabric. Mild soap and water will remove most contaminants. If necessary, mineral spirits may be used to remove grease or oil. Do not use any other cleaning products. Do not use cleaning agents that contain bleach! Avoid agitating the canopy, especially when wet. Agitation will cause reduction in canopy performance.

Zero Porosity Fabric - the ZP fabric is not affected by water. However, the reinforcement tapes may be. All tapes used in these canopies are pre-shrunk at the factory to make them more dimensionally stable. However, if they get wet they can shrink and change in length. Small changes in reinforcement tape dimensions can result in rather significant geometry change of the canopy, resulting in large change in canopy performance. To maintain the best performance, avoid getting the canopy wet. Water jumps are not recommended.

If you need to clean your canopy, please wash only the contaminated areas. Use a mild soap and water only. Oil and grease usually do not penetrate the coating surface so solvents are not normally necessary. Also, some solvents may affect the coating. Avoid getting the reinforcing tapes wet if possible. Do not machine wash.