

**LIMITED URGENT**

**\*MWO 10-1670-292-30-1**

MWO effective date 23 July 1992 and completion date 21 January 1993.

**MODIFICATION WORK ORDER**

---

**MODIFICATION OF STEERING ORIFICE  
FOR  
MC1-1C PARACHUTE  
NSN 1670-01-262-2359**

---

**21 July 1992**

---

Approved for public release; distribution is unlimited.

**REPORTING ERRORS AND RECOMMENDING IMPROVEMENTS**

You can help improve this manual. If you find any mistake or if you know of a way to improve the procedure, please let us know. Mail your letter, DA Form 2028 (Recommended Changes to Publications and Blank Forms), to: Commander, U. S. Army Troop Support Command, ATTN: AMSTR-MMTS, 4300 Goodfellow Boulevard, St. Louis, MO 63120-1798. A reply will be furnished directly to you.

**1. Purpose of Modification.** The purpose of this modification is to prevent canopy flow-through in the steering orifice.

**2. Priority Classification.** This modification is classified as LIMITED URGENT.

a. Equipment in Use: Equipment in use will be modified as soon as possible, and no later than the scheduled completion date. Equipment not modified after the expiration of the Modification Work Order (MWO) completion date will be reported as Not Mission Capable (NMC), in accordance with applicable Army regulations.

b. Equipment in Wholesale Depot Supply or Maintenance Activities. The MWO will be accomplished on serviceable material prior to issue and/or subsequent to the scheduled completion date. Issue of unmodified material is prohibited. The MWO will be applied to unserviceable material during scheduled Depot Maintenance.

**3. End Item or System to be Modified.** The following end items shall be modified in accordance with the instructions contained in Paragraph 10.

<b>Nomenclature</b>	<b>National Stock Number</b>	<b>Mfg./Hull No.</b>
MC1-1C Parachute	1670-01-262-2359	N/A

**4. Modules (Components, Assemblies, Subassemblies, Boards, and Cards) to be modified.** Not applicable.

**5. Part to be modified.** Canopy, personnel, with net and orifice, MC1-1C.

**6. Application.**

a. Time Compliance Schedule. The MWO time compliance period begins on 23 July 1992. The completion date is 21 January 1993.

b. Level of Maintenance: Unit.

\*This MWO supersedes MWO 10-1670-292-30-1, dated 21 January 1992.

- c. Applied By: Parachute Rigger, MOS 43E.
- d. Time Required: (Time for completion of MWO application to one end item.)
  - (1) Total of 1 workhour.
  - (2) Total of 1 workhour downtime for one end item.
- e. MWO to be applied to or concurrently with this MWO: None.

**7. Technical Publications.** Affected/changed as a result of this MWO.

**TM 10-1670-292-23&P.**

**8. Supply Kits/Parts and Disposition.**

- a. MWO kits supplied by: Not applicable.
- b. National Stock Number for MWO kit: Not applicable.
- c. MWO kits authorized only for: Not applicable.
- d. Bulk and Consumable: Tape, nylon, Type II111, 1 1/2 inch, MIL-T-5083, OD. Thread, nylon, Size E, V-T-295.
- e. Parts Disposition: Not applicable.

**9. Special Tools, Jigs, Test, Measurement and Diagnostic Equipment (TMDE); and Fixtures Required.**  
**Not applicable.**

**10. Modification Procedures.** Refer to Appendix A.

**11. Calibration Requirements.** Not applicable.

**12. Weight and Balance Data.** Not applicable.

**13. Quality Assurance Requirements.** Inspection of the completed MWO application for full compliance with the technical requirements of the instructions will be accomplished by qualified personnel.

**14. Recording and Reporting of the Modification Records and Report Forms.** Completion of DA Form 2407 will be in accordance with DA PAM 738-750. The hull number to be reported in Block 2 must be in the hull range stated in Paragraph 3 of this MWO. The NSN for End Items to be reported in Block 6 must be the same as the NSN shown in paragraph 3. The NSN of the item actually modified will be entered in Block 20h. This NSN must match the NSN shown in Block 6. The Unit Identification Code to be reported in Block 1c must be the six character code that is put on the Unit/Organization shown in Block 1 a. (Normally, this will be the code that is put on the Unit/Organization Morning/Report.) if more space is needed, use DA Form 2407. After completing the form, mail the National Maintenance Point (Copy 2) to: Commander, U.S. Army Troop Support Command, ATTN: AMSTR-MMDD, 4300 Goodfellow Boulevard, St. Louis, MO 63120-1798. Mail the Control Copy (Copy 3) to: Commander, U.S. Army Depot System Command, ATTN: AMSTR-PM, Chambersburg, PA 17201, for PAC 98 (Non-AAIF Field Activities). Forward the Organizational Copy (Copy 4) as directed by the local commander.

**15. Materiel Change (MC) No. 1-91-8-3506.**

**16. Narrative and Graphic Description of MWO.** Refer to Appendix A.

**APPENDIX A  
INSTRUCTIONS FOR  
REWORK OF MC1-1C CANOPIES**

**1. Estimate of time to modify MCI-IC parachute with reinforcement modification.**

- a. Layout, mark and cut reinforcement tape: 45 minutes.
- b. Install reinforcement tape: 10 minutes.
- c. Inspect parachute for return to service: 5 minutes.
- d. Total time on the second or more canopy worked on (reflects use of 308 zig-zag sewing machine): 1 hour.

**2. List of Materials/Tools Required:**

- a. Scissors: 1 pair.
  - b. Sewing Machine, Light Duty Singer Zig-Zag, or Equivalent: 1 each.
  - c. Approved Marking Pen: 1 each.
  - d. "T" Pins and Weights: as required.
  - e. Tape Measure, T-Square, or Framing Square: 1 each.
  - f. 1 1/2 Inch Type III, Class 1 or 2 OD Tape, MIL-T-5083 (NSN 8315-00-753-5952): 1 roll.
  - g. Thread, Size E, conforming to V-T-295, Type 1, 2, or 3: 1 spool.
3. The method for attaching tapes shall be 13-15 points per Inch in a double throw zig-zag 308 pattern, 1/4 inch wide within 1/8 inch of the radial tape edges, in accordance with FED-STD-751.

**4. Instructions.** Reinforcement modifications must be made to each of the two (2) steering orifices located in gores # 4 and # 26 for each parachute. The procedures given below are for only one (1) gore. Repeat the entire procedure for the other gore.

**a. Prefabrication of Reinforcement Tapes:**

(1) Measure and cut the 1 1/2-inch tape into one (1) 30-inch length and one (1) 32-inch length. Mark the center of each length. Mark at 1/2-inch from each end of each length for later tum-under.

(2) Measure and cut the 1 1/2 inch tape into one (1) 33 3/4-inch length. Designate one end as the top and mark with a "T". Mark the tape 2 1/2-inches from the top and at 17 1/2-inches from the top. Mark at 1/2-inch from each end for later tum-under.

(3) Lay out the 33 3/4 inch length of tape. Center the 30 inch length of tape over the 33 3/4-inch length of tape, centering it over the 17 1/2-inch mark. Sew the centersection where the tapes cross with two (2) rows of stitching as specified in paragraph 3 above.

(4) Center the 32 inch length of tape over the 33 3/4 inch length of tape, 1/2-inch up from the bottom of the 33 3/4-inch length of tape. Turn under the bottom 1/2-inch of the tape, folding it between the two (2) tapes.

Sew the center section where the tapes cross with two (2) rows of stitching as specified in paragraph 3 above.

**b. Attaching Reinforcement Tapes to the Parachute.**

(1) Position parachute assembly on packing table in proper layout per TM 10-1670-292-23&P, without tension. Inspect for damage. Any damage should be repaired while parachute is down for installation of reinforcement tapes.

(2) Select gore # 4 or #26 to be modified. Move all other gores out of the way, aligning the gore to be modified over gore # 15.

(3) Work the floating material on the radial seams on either side of the orifice and gore # 15 from the skirt area toward the vent. Matching the lower lateral bands and the radial seams of both gores will allow the desired shape to form for the gore to be worked. Use v' pins and weights to secure the gore in the proper position.

(4) Establish a center line on the Inside of gore # 15. Measure down and mark 15-inches and 30-inches on the center line.

(5) Project these marks 90 degrees (right angles) from the center line to each side of the large orifice in the gore being worked on, and mark it.

(6) Lay the prefabricated reinforcement tape over the orifice in the gore to be worked on, as shown in the drawing. Locate the top of the 33 3/4-inch length of tape over the center line and line up so that the 2 1/2-inch mark is flush with the binding tape at the top of the orifice. Turn under the first 1/2-inch of the tape and sew the tape to the parachute gore as shown in View B using the specified stitch pattern. The stitch pattern which captures the binding tape should overextend the tape by 1/2-inch, as shown.

(7) Locate the 30-inch and 32-inch lengths of tape at the sides of the orifices centered on the marks made at 15-inches and 30-inches, respectively. Turn under first 1/2-inch of the tape ends, and sew the tapes through the floating tape in the sides of the orifices as shown in View C using the specified stitch pattern, extending beyond the tape ends by 1/2-inch on each side shown.

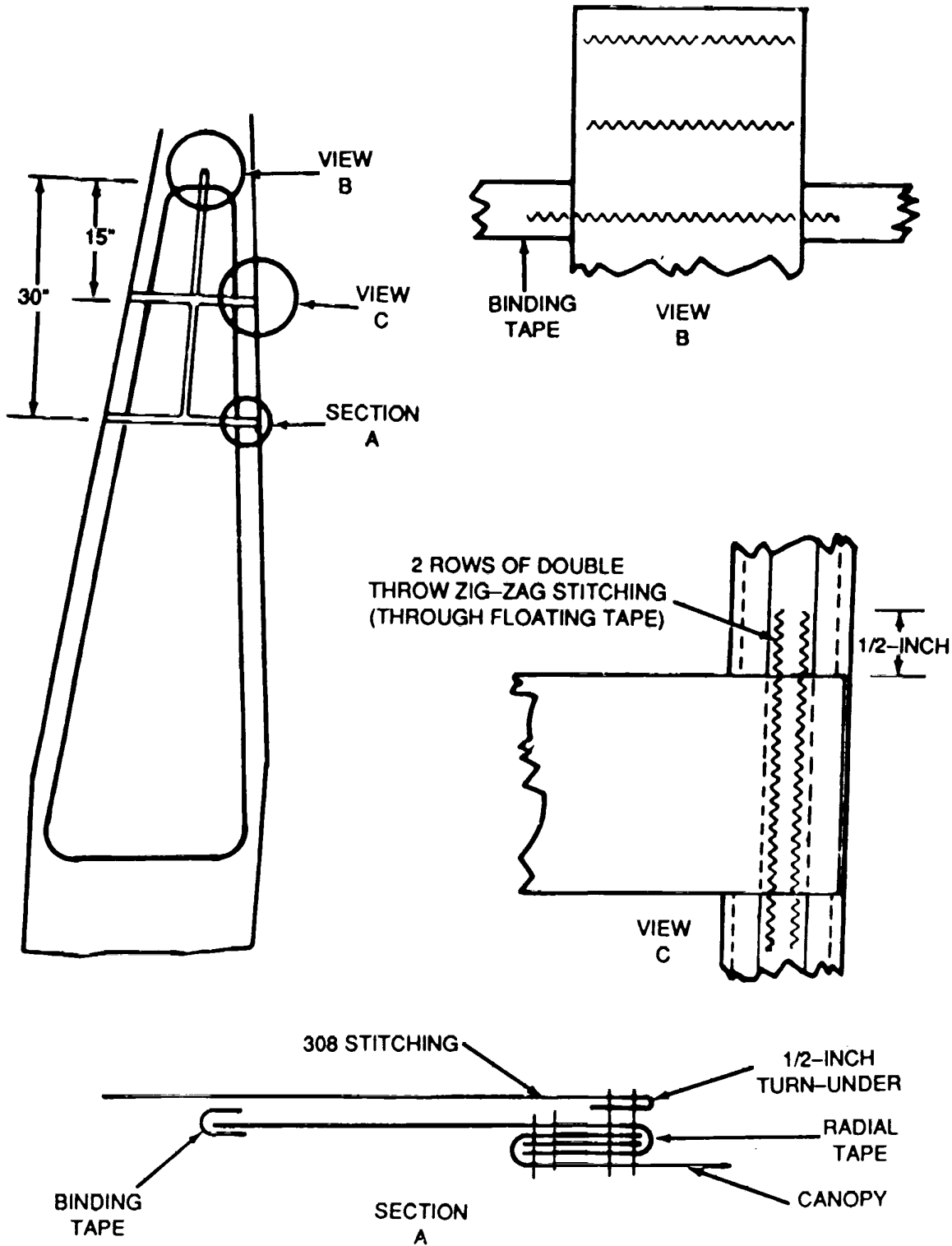

MWO 10-1670-292-30-1

By Order of the Secretary of the Army:

GORDON R. SULLIVAN  
*General, United States Army*  
*Chief of Staff*

Official:   
MILTON H. HAMILTON  
*Administrative Assistant to the*  
*Secretary of the Army*  
02402

**DISTRIBUTION:**

To be distributed in accordance with DA Form 12-25-E, block 5413,  
requirements for MWO 10-1670-292-30-1.

RECOMMENDED CHANGES TO EQUIPMENT TECHNICAL PUBLICATIONS



**SOMETHING WRONG WITH PUBLICATION**

FROM: (PRINT YOUR UNIT'S COMPLETE ADDRESS)

DATE SENT

PUBLICATION NUMBER

PUBLICATION DATE

PUBLICATION TITLE

BE EXACT PIN-POINT WHERE IT IS

PAGE NO.

PARA-GRAPH

FIGURE NO.

TABLE NO.

IN THIS SPACE, TELL WHAT IS WRONG AND WHAT SHOULD BE DONE ABOUT IT.

TEAR ALONG PERFORATED LINE

PRINTED NAME, GRADE OR TITLE AND TELEPHONE NUMBER

SIGN HERE

# The Metric System and Equivalents

## Linear Measure

1 centimeter = 10 millimeters = .39 inch  
 1 decimeter = 10 centimeters = 3.94 inches  
 1 meter = 10 decimeters = 39.37 inches  
 1 dekameter = 10 meters = 32.8 feet  
 1 hectometer = 10 dekameters = 328.08 feet  
 1 kilometer = 10 hectometers = 3,280.8 feet

## Weights

1 centigram = 10 milligrams = .15 grain  
 1 decigram = 10 centigrams = 1.54 grains  
 1 gram = 10 decigrams = .035 ounce  
 1 dekagram = 10 grams = .35 ounce  
 1 hectogram = 10 dekagrams = 3.52 ounces  
 1 kilogram = 10 hectograms = 2.2 pounds  
 1 quintal = 100 kilograms = 220.46 pounds  
 1 metric ton = 10 quintals = 1.1 short tons

## Liquid Measure

1 centiliter = 10 milliliters = .34 fl. ounce  
 1 deciliter = 10 centiliters = 3.38 fl. ounces  
 1 liter = 10 deciliters = 33.81 fl. ounces  
 1 dekaliter = 10 liters = 2.64 gallons  
 1 hectoliter = 10 dekaliters = 26.42 gallons  
 1 kiloliter = 10 hectoliters = 264.18 gallons

## Square Measure

1 sq. centimeter = 100 sq. millimeters = .155 sq. inch  
 1 sq. decimeter = 100 sq. centimeters = 15.5 sq. inches  
 1 sq. meter (centare) = 100 sq. decimeters = 10.76 sq. feet  
 1 sq. dekameter (are) = 100 sq. meters = 1,076.4 sq. feet  
 1 sq. hectometer (hectare) = 100 sq. dekameters = 2.47 acres  
 1 sq. kilometer = 100 sq. hectometers = .386 sq. mile

## Cubic Measure

1 cu. centimeter = 1000 cu. millimeters = .06 cu. inch  
 1 cu. decimeter = 1000 cu. centimeters = 61.02 cu. inches  
 1 cu. meter = 1000 cu. decimeters = 35.31 cu. feet

## Approximate Conversion Factors

To change	To	Multiply by	To change	To	Multiply by
inches	centimeters	2.540	ounce-inches	newton-meters	.007062
feet	meters	.305	centimeters	inches	.394
yards	meters	.914	meters	feet	3.280
miles	kilometers	1.609	meters	yards	1.094
square inches	square centimeters	6.451	kilometers	miles	.621
square feet	square meters	.093	square centimeters	square inches	.155
square yards	square meters	.836	square meters	square feet	10.764
square miles	square kilometers	2.590	square meters	square yards	1.196
acres	square hectometers	.405	square kilometers	square miles	.386
cubic feet	cubic meters	.028	square hectometers	acres	2.471
cubic yards	cubic meters	.765	cubic meters	cubic feet	35.315
fluid ounces	milliliters	29.573	cubic meters	cubic yards	1.308
pints	liters	.473	milliliters	fluid ounces	.034
quarts	liters	.946	liters	pints	2.113
gallons	liters	3.785	liters	quarts	1.057
ounces	grams	28.349	liters	gallons	.264
pounds	kilograms	.454	grams	ounces	.035
short tons	metric tons	.907	kilograms	pounds	2.205
pound-feet	newton-meters	1.356	metric tons	short tons	1.102
pound-inches	newton-meters	.11296			

## Temperature (Exact)

°F Fahrenheit temperature      5/9 (after subtracting 32)      Celsius temperature      °C



**PIN# 069028-000**