

OWNERS MANUAL

RTS

MIRAGE SYSTEMS

TABLE OF CONTENTS

Introduction	1
User Warning	2
Packing Instructions for Ram Air Reserve with Freebag	3
Assembly of RSL (optional)	15
The 3-Ring Release System	17
Assembly of Centerline Collapsible Pilot Chute	22
Assembly of Standard Pilot Chute	25
Closing the Fly-Open BOC	26
Attaching the Main D-Bag and PC	27
Packing Instructions for Main Container	28
Proper Routing of Main Pilot Chute Bridle	31
Main Closing With Ripcord	32
Packing Instructions for Main Pilot Chute	34
Maintaining Your RTS	35
Replacement Parts	37
User Instructions	38

INTRODUCTION

Congratulations on your purchase of an RTS training harness/container system by Mirage Systems. The RTS is the finest training harness/container system available anywhere, and with proper care and use it will last for many years. It is the purpose of this manual to provide you with the information necessary to enable you to care for and use your RTS properly. It is our hope you and your students will enjoy your RTS as much as we enjoyed building it for you. Should any aspect of the information contained in this manual be unclear to you, or should you have questions or concerns about your RTS which are not addressed by this manual, you are encouraged to contact Mirage Systems Inc. at the address below or on the back cover of this manual prior to using the RTS. The purpose of this manual is to familiarize the RTS owner and rigger with the function and packing procedures of the RTS system. It is not a substitute for a course of instruction, nor does it release the owner or user from responsibility for the use and maintenance of the system or from the responsibility to train students to use the system safely and properly. Although packing instructions are included for the reserve parachute, note that this operation is governed by applicable laws, and may not be legally conducted by anyone other than a certificated rigger. Mirage Systems Inc. is not responsible for use of the RTS with any parts not specifically supplied by Mirage Systems Inc. for your RTS, nor for the use of the RTS with any other canopies than those specifically mentioned as compatible on the system information panel inside the main pack tray. If there are any questions about equipment compatibility, please contact Mirage Systems Inc.

Mirage Systems Inc,

P.O. Box 820

DeLand, FL 32724

info@miragesys.com

WARNING

Low Speed Parachute

Limited to use from
Airplane under 150 mph

Skydiving is a hazardous activity that can result in injury or death.

Parachutes sometimes malfunction even though they are properly designed, built, assembled, packed, maintained and used. The results of such malfunctions are sometimes serious injury or death.

If you use your RTS, or allow someone else to use it, you are acknowledging sport parachuting's risks and accepting the fact that the RTS and /or its components may malfunction.

If you are not willing to accept the risks of sport parachuting, or if you are not willing to accept the possibility that your RTS or its components may malfunction and perhaps cause you to be injured or killed, then you should reconsider your involvement in sport parachuting.

Training and/or experience are required to lower the risk of serious bodily injury or death.

Never use the RTS unless you have read and understand this warning, and

- A. you have completed a "Controlled Program of Instruction" in the use of this equipment or
- B. you have read and understand all appropriate flight manuals and packing instructions.

To lower the risk of death, serious bodily injury, canopy damage, container damage and hard openings, never exceed 130 kts. deployment speed.

Packing the Reserve Container

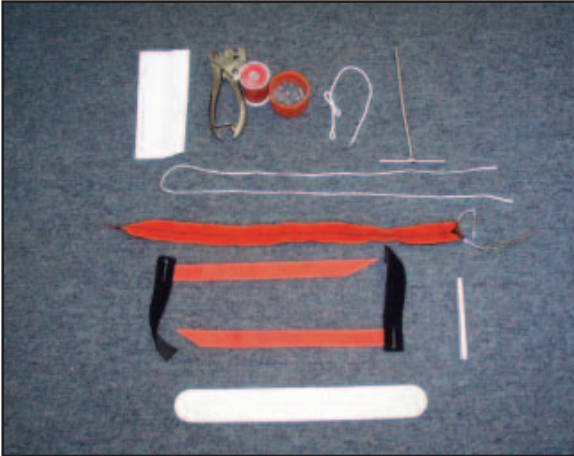

Fig. 1

TOOL LIST

1. Complete RTS packing data card
2. Lead seal, press, and thread
3. Cypres loop, washer, and silicon
4. Bodkin/T-bar
5. Long pull up cord
6. Temporary pin
7. Temporary pile velcro tabs
8. Leverage Bar or Packing Paddle [Fig. 1]

Helpful Hint: Count and keep track of your tools!



Fig. 2

Installing the Cypres processing unit

(Also see the Cypres installation manual)

For installation, the processing unit is placed into a specially bolstered and labeled nylon pocket which is pre-installed in every RTS reserve container.

Excess cable is stowed in the flat part of the pocket underneath the velcro-adjustable flap. If you have to stow both the thinner EOS cable and the thicker cable to the control unit, be sure to place the thicker cable so that it lays on top of the thinner one. [Fig. 2]



Fig. 3

Installing the EOS and Cypres Control Unit

Feed the EOS and Control unit through the opening up the built in channel in the reserve pack tray.

The EOS cable is routed through the small slit on the #1 closing flap and into the Cypres channel. Secure the EOS using the elastic keeper. Insert the control unit into the pouch with the clear window on the yoke of the rig.

[Fig. 3]

Packing the Reserve Container



Fig. 4

Attach the square reserve to the container system. Attach the steering toggles, set the deployment brake length according to canopy manufacturers instructions. [Fig. 4]



Fig. 5

Stow excess reserve canopy steering line in velcro keeper. Mate toggle to velcro on reserve risers. Repeat on opposite riser. [Fig. 5 & 6]



Fig. 6



Fig. 7

Attach temporary pile velcro tabs to the hook side of velcro on the line stow pocket of reserve freebag. Thread Bodkin/T-Bar with pull up cord through center #2 grommet to the backside of the freebag. [Fig. 7]

WARNING: Hook velcro may damage suspension lines.

Helpful Hint: Attach the pull up cord to the safety stow and Bodkin to hold in place.



Fig. 8

Thread looped end of bridle through pilot chute loops, then pass freebag through looped end of bridle to form a larks head knot. Center bridle on pilot chute loops and cinch very tight. [Fig. 8]

Packing the Reserve Container



Fig. 9

Fold canopy in accordance to canopy manufacturers instructions. Mirage Systems recommends P.R.O. pack style. After flaking and laying the container down, insure that all suspension lines are placed into the center of the canopy. Centering the suspension lines improves deployment. All suspension lines should be centered the entire length of the cocoon. [Fig. 9]



Fig. 10

Cocoon the canopy to the width of the reserve freebag mouth lock. Canopies cocooned wider may increase bulk. [Fig. 10]



Fig. 11

The first fold places the slider grommet on the edge of the canopy. [Fig. 11]

Helpful Hint: This fold is usually 3-6 inches, depending on the canopy size.

Packing the Reserve Container



Fig. 12

The second S fold is placed over the first fold. This begins to create the desired wedge shape of the reserve container. [Fig. 12]

Helpful Hint: The second fold should be 6-8 inches overall. The majority of the bulk should be towards the bottom of the reserve container.



Fig. 13

Pull remaining center cell back creating the MOLAR shape [Fig. 13]

Helpful Hint: Rolling what is left of the center cell back, along with distributing this fabric left and right makes a good MOLAR shape.



Fig. 14

Helpful Hint: Larger canopies tend to have long MOLAR "ears" and may need to be folded under. The normal range is 3-6 inches. REMEMBER the RTS reserve container prefers the bulk toward the bottom. [Fig. 14]

Packing the Reserve Container



Fig. 15

Place canopy onto the freebag. [Fig. 15]

Helpful Hint: After placing canopy on the bag work one side at a time into the freebag. Insure the bodkin is between the MOLAR "ears".



Fig. 16

Close the freebag mouth lock using the safety stow. [Fig. 16]

Helpful Hint: The microline lock stows should be 2 inches, Dacron line lock stows may require up to 3".



Fig. 17

Insert all but 4 inches of the remaining lines into the line stow pocket in a S fold manner, starting at the very bottom of the pocket.

[Fig. 17]

Helpful Hint: Remember to remove the pile velcro tabs and mate the velcro in the pocket. Make sure not to trap any lines in between the velcro halves. To reduce line bulk, distribute the lines evenly throughout the line pocket.

Packing the Reserve Container

Reserve Closing Loop	
Canopy Size	Loop Length
PD-160 rsv	4.50" +/- 1/4"
PD-176 rsv	4.75" +/- 1/4"
PD-193 rsv	5.25" +/- 1/4"
PD-218 rsv	6.00" +/- 1/4"
PD-253 rsv	6.00" +/- 1/4"

Fig. 18

Here is a suggested reserve closing loop length chart. Prestretched loops are measured from the washer to the end of the closing loop. [Fig. 18]

IMPORTANT: Reserve ripcord pull force must remain under 22 lbs. pull force.

Helpful Hint: A label in the main packing tray lists the canopies that are compatible with the container. Also included are more recommendations on closing loop length.



Fig. 19

Pull Bodkin/T-Bar and pull up cord through the freebag. Then thread pull up cord through closing loop. Tie off with bowline knot about 6 inches up. [Fig.19]

Helpful Hint: Treat pull up cord and top 1/2 inch of the closing loop with Airtec approved silicon. Airtec recommends the use of silicon to protect the Cypres loop. It also helps with reserve pin insertion.



Fig. 20

Place the reserve freebag into the reserve pack tray and align risers. [Fig. 20]

Packing the Reserve Container

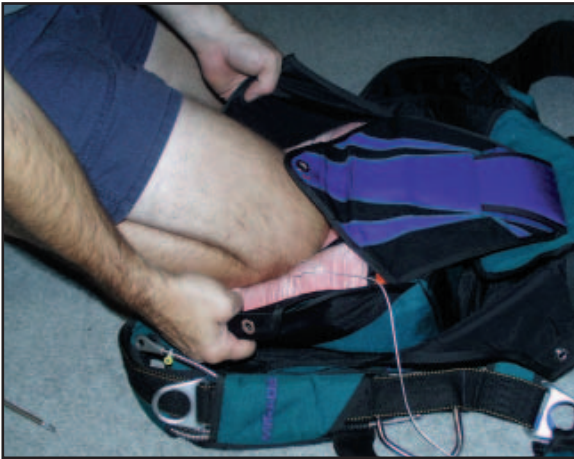

Fig. 21

Push freebag into the reserve container, filling the corners and making space for the reserve pilot chute. [Fig. 21]

Helpful Hint: Place your knee on the center freebag grommet while pulling up on the #4 and #5 side flaps, and work the canopy into the corners and away from the center grommet. This is important for bulk distribution and proper pilot chute seating and should be repeated often.



Fig. 22

Starting at bridle line attachment point on freebag, lay bridle as shown in Fig. 22. While distributing, remove any twists in the bridle. Fold all but 3-4 ft of the bridle under the #1 closing flap [Fig. 23].



Fig. 23



Fig. 24

Thread closing loop and pull up cord through Cypres cutter and #1 closing flap. Use temporary pin to pin closing loop in place. [Fig. 24]

Helpful Hint: Placing your foot on the #1 closing flap while pulling up on the #4 and #5 side flaps, works the canopy into the corners and away from the closing loop. This is important for bulk distribution and proper pilot chute seating and should be repeated often. Main riser covers may be used after reserve side flaps are closed.

Packing the Reserve Container



Fig. 25

Distribute the remaining 3-4 ft of bridle on top of the #1 closing flap.[Fig. 25]



Fig. 26

Thread pull up cord through the spring pilot chute. Center the pilot chute base over the #1 closing flap grommet. [Fig. 26]



Fig. 27

While keeping all pilot chute fabric out of the spring, compress the pilot chute. [Fig. 27]

Helpful Hint: Holding the pull up cord in mouth will help control the spring. The pull up cord helps guide the pilot chute while you compress with your hands.

Packing the Reserve Container



Fig. 28

Using a leverage bar with the pull up cord for leverage, pull the closing loop up through the #2 pilot chute cap closing sequence. Pin using the temporary closing pin. [Fig. 28]

IMPORTANT: There should not be pilot chute fabric inside of the compressed coils of the spring.

Helpful Hint: If an actual leverage bar is not available, a wrench or packing paddle can be used.



Fig. 29

After pilot chute cap is pinned, force the pilot chute down into the reserve freebag. [Fig. 29]

Helpful Hint: Placing your foot on the #2 reserve pilot chute while pulling up on the #4 and #5 side flaps, works the canopy into the corners and away from the closing loop. This is important for bulk distribution and proper pilot chute seating and should be repeated often. Main riser covers may be used after reserve side flaps are closed.



Fig. 30

Accordion fold both halves of the pilot chute canopy, making one long tube. Thread pull up cord through flap #3 [Fig.30]

Packing the Reserve Container



Fig. 31

Place your foot on top edge of the reserve pilot chute cap. Push the pilot chute towards the bottom while pulling the #3 flap closed. Remove and replace temporary pin. [Fig. 31]

Helpful Hint: Remember to remove the temporary pin once the grommets are touching. With adequate pressure to contain the pilot chute, the temporary pin can be removed and repositioned to the #3 closing flap.



Fig. 32

Once #3 flap is pinned, force the pilot chute down into the freebag. [Fig. 32]

Helpful Hint: Placing your foot on the #3 closing flap while pulling up on the #4 and #5 side flaps, works the canopy into the corners and away from the closing loop. This is important for bulk distribution and proper pilot chute seating and should be repeated often. Main riser covers may be used after reserve side flaps are closed.



Fig. 33

Thread the pull up cord through both #4 and #5 closing flaps. While using the leverage bar, draw #4 and #5 grommets towards the center. Do not remove temporary pin yet. [Fig. 33]

Important: Do not force grommets into center. Work gradually using the helpful hint technique

Helpful Hint: While pulling the flap toward the center, slap the flap on the reserve side wall seam. This method will gradually move the grommet closer to the center without damaging the container. Working both side flaps together will also help keep the reserve container symmetrical.

Packing the Reserve Container



Fig. 34

Once the #4 and #5 side flap grommets are drawn towards the center over the closing loop, unthread the #5 flap. Keep pressure on the #4 flap and once again reposition the temporary pin onto the #4 closing flap. [Fig. 34]. After closing flap #4, close flap #5. Remove and reposition the temporary pin.

Helpful Hint: The RTS pilot chute spring produces up to a 40lb. spring force. REMEMBER to keep adequate pressure to contain it while repositioning the temporary pin.



Fig. 35

Once #5 flap is pinned, work the pilot chute down into the freebag. [Fig. 35]

Helpful Hint: Placing your foot on the #4 and #5 closing flaps while pulling up on the main riser covers, works the canopy into the corners and away from the closing loop. These repeated processes will help make the reserve pin cover have a smoother, flatter look. Any bowing could allow air to untuck the flap, exposing the reserve pin.



Fig. 36

Thread the pull up cord through the #6 closing flap. While pulling the closing loop up through the #6 closing flap remove the temporary pin. Pin the closing loop with the reserve ripcord pin. [Fig. 36] If you are installing an RSL, see the RSL assembly section in this manual.

Helpful Hint: If you are having difficulty getting the reserve ripcord pin through the closing loop, use the temporary pin and work the container more. Waiting 15+ minutes and repeating Fig. 34 will make inserting the reserve ripcord pin easier on the second try. There should be VERY little bowing with this flap. This flap should lay as flat as possible. The #6 flap has the best results if it is slightly concave from flaps #4 and #5. Repeat Fig. 34 to shift the bulk out from under the #6 closing flap if needed.

Packing the Reserve Container



Fig. 37

Before sealing the container, count and inspect ALL tools that were used. [See Fig.1]

Seal reserve pin with 5 lb. seal thread. [Fig. 37]

IMPORTANT: Do not forget to replace the completed packing data card in the proper pocket.

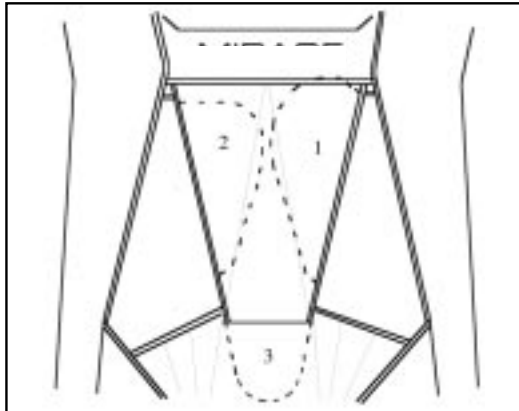

Fig. 38

Close the reserve pin cover using all three tuck tabs. [Fig.38]

Helpful Hint: Tucking the right (#1), larger tab under first then the smaller left (#2) will make it easier to close. Remember to tuck the bottom of the reserve pin cover into the center flap pocket (#3).



The RSL System

The Reserve Static Line System (RSL) is standard equipment on the RTS harness/container. To properly use a system equipped with an RSL, you must be familiar with its assembly, operation and function. Students must also receive training from competent instructors prior to using such a system. It is not the intention of this manual to provide such training.

FUNCTION

The RSL system consists of a lanyard between the left main riser and the reserve ripcord. It is designed to use the mechanical force of the released main risers after a cutaway to pull the reserve ripcord pin. It is not guaranteed to function properly and should not be relied on to activate your reserve canopy.

OPERATION

The RSL is essentially a passive system. A release lanyard is provided to disconnect the system. Use and operation of the system should be explained by competent instructors.

Assembly of the RSL



Fig. 1

Mate 1/2" hook and pile Velcro on the RSL lanyard. [Fig.1]

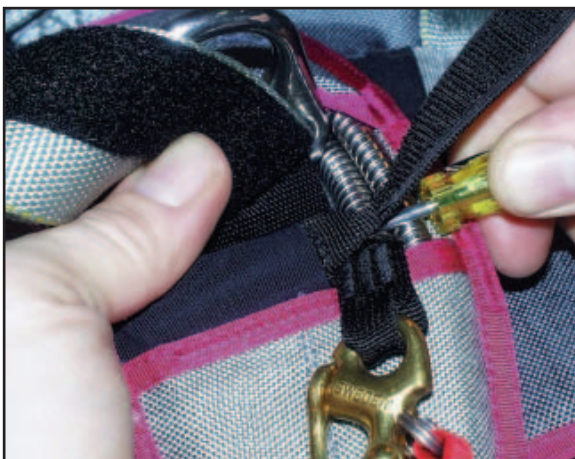

Fig. 2

Insert RSL lanyard in the provided spandex pocket located behind the reserve riser at the large main riser ring. [Fig. 2]

Helpful Hint: A small screw driver point between the velcro will help guide the RSL lanyard as you push it into the spandex pocket.

The RSL System



Fig. 3

Mate 5/8" hook Velcro to rear reserve riser. [Fig. 3]



Fig. 4

Attach the snap shackle to the main riser RSL ring and inspect routing. The RSL shackle must not interfere with the operation of the 3-Ring System. [Fig. 4]



Fig. 5

Prior to closing flap #6, thread reserve ripcord through the RSL rings [Fig.5], with the ring on the RSL lanyard between the two rings on flap #6. After closing flap #6, neatly tuck the excess lanyard under the reserve closing flap.

IMPORTANT: Proper configuration of the reserve ripcord through the RSL rings is critical to the proper function of the RSL system!

The 3-Ring Release System

3 RING HISTORY

The 3-Ring Release System was invented in 1976. It was the first practical release that allowed parachutists to jettison their main canopies in one motion by simply pulling a single handle. Not only is the 3-Ring easier to operate than previous canopy release systems, it is also more reliable. Once the main is jettisoned, the only things left on the harness are two smooth rings that cannot snag a deploying reserve. Some other release systems can - and have - interfered with the deploying reserve.

MODIFYING THE 3-RING RELEASE

The great reliability of the 3-Ring system results from the proper functioning of every one of its individual components. The owner should not modify the system in any way, nor should he or she replace genuine 3-Ring parts with others.

These modifications (among others) may cause the system to not work properly:

- Substituting risers that don't have Type 2 sheathing for the locking loop. Don't use risers that have loops made of Kevlar or solid cord. The loop should be white and flat.
- Not using a breakaway handle with cable with the special yellow coating. This Teflon-impregnated coating is important; other plastic coatings may cause the cables to bind in the housings or loops, making it difficult or impossible to jettison the risers.
- Using a breakaway handle with cables of the wrong length. The length of the cables is critical to insure each riser releases in the proper sequence. There should be a minimum of 5.5" up to a maximum of 7" of cable past the cable housing end (start measuring where the cable comes out of the cable housing end). Mirage Systems trims to 6" as of Nov. 1, 1998. Replacement handles are available from Mirage Systems or your authorized dealer.

UNDERSTANDING THE 3-RING RELEASE SYSTEMS

Knowing how the 3-ring release systems works will help you assemble and inspect it properly.

Begin by peeling the release handle from the Velcro pocket on the harness. Peeling, rather than pulling, makes it easier to separate the handle from the webbing. Look behind the risers near the harness and observe the movement of the yellow cable as you pull the handle. When the cable clears the white loop, release is engaged. Now slowly pull one of the risers off the harness. As you pull, you'll notice that the white loop gets pulled through the grommet by the action of the smallest ring. Each ring forms a lever with a ten-to-one mechanical advantage as it passes through the other. A force of 1,000 pounds on the large harness ring exerts a force of only 10 pounds on the white loop. (Opening shock usually totals about 1,000 pounds or 500 pounds on each riser.)

Because of the mechanical advantage provided by the 3-Ring design, only a force of approximately one pound on the top ring keeps the release together. That's why it's important to keep foreign matter like bits of grass and sticks out of the 3-Ring assembly. A small stick in the white loop could prevent a riser from releasing. It is also important to understand one of the properties of the nylon components of the system. When nylon stays in the same position for a long time, it begins to conform to that position, or take a "set." If the 3-Ring release system stays assembled for too long, the nylon can become so stiff that the low drag from a malfunction (such as a streamer) won't pull the riser off the ring. The 3-Ring release system must be disassembled, flexed and inspected every month. Procedures for this are listed in the 3 ring maintenance section of this chapter.

The 3-Ring Release System

USE OF MIRAGE SYSTEMS ARMORED RISERS

Mirage Systems incorporated the use of our Armored Risers Feb. 2000. Twisting risers can trap the excess release cable inside the risers fabric channel, inhibiting you from pulling the breakaway handle. Mirage Systems designed risers with a hard housing inside the channel on the back of the riser to stow the excess release cable. These Armored Risers decrease the amount of cable that is exposed and the hard housing reduces the likelihood of the riser release cable entrapment malfunction.

Care and maintenance for the Armored Riser should include all the same procedures for non Armored Risers, but should also include routine inspection of the hard housing channel entrance hole. Through normal wear the hole should not increase in diameter. If the housing can be pulled through the opening, the riser should be replaced.



Assembly of the 3-Ring Release System



Before assembling the 3-Ring release, make sure the risers aren't twisted or reversed. Lay the RTS face down, as you would to pack it. Thread each cable into its housing and mate the handle to the harness. The handle should be positioned as close to the ends of the housings as possible so that no cable is exposed.

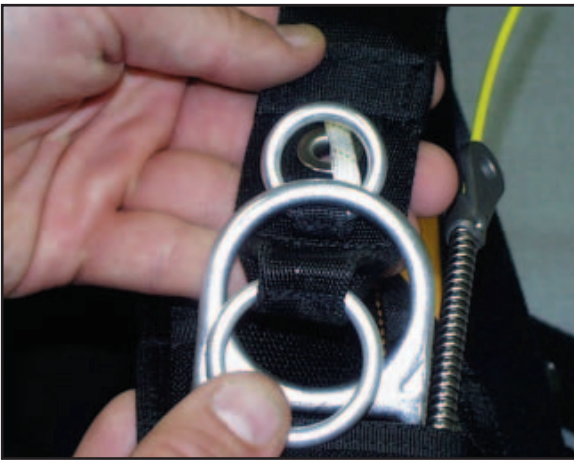

With the rings of the riser facing forward, pass the large ring on the end of the riser through the large harness ring from above. Fold it back toward the canopy and risers. [Fig.1]

Fig. 1

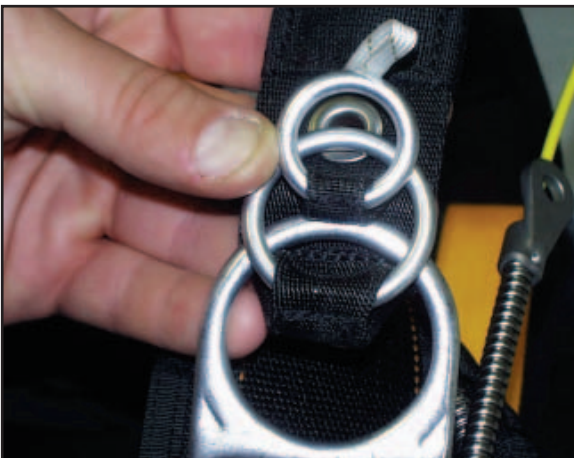

Thread the smallest ring through the middle ring in the same way, but make sure it doesn't pass through the large ring. [Fig. 2]

Fig. 2

Assembly of the 3-Ring Release System



Fig. 3

Bring the white loop over the small ring only and then through the riser grommet so it pokes out the back of the riser. [Fig. 3]

IMPORTANT: For the proper leverage reduction, the white loop must only travel over the smallest ring.



Fig. 4

Continue threading the white loop through the end fitting on the cable housing. The flat side of the end fitting should be against the riser. [Fig. 4]



Fig. 5

Thread the yellow cable through the white loop, making sure the loop isn't twisted. Be careful with the cable so you don't bend it too sharply or kink it. Insert the free end in the channel on the back of the riser. There should be plenty of excess cable with the cutaway handle securely mated to the harness. [Fig.5]

Repeat the above steps with the other riser.

The 3-Ring Release System

PRE-JUMP INSPECTION FOR THE 3-RING RELEASE

- 1) Each ring passes through only one other ring.
- 2) The white loop passes through only the small ring.
- 3) The white loop passes through the end fitting on the cable housing without twisting
- 4) Nothing passes through the white loop except the yellow cable
- 5) The 3-Ring release handle is securely mated to the harness, and little cable is visible between the handle and the cable housings. If your release handle has a tendency to hide itself under your main left web, undo the Velcro and twist the handle in a counter-clockwise rotation (when wearing rig) so the handle will stick-out and slightly forward for a better grip.

USE OF NON-FACTORY RISERS

If the RTS is fitted with 3-Ring risers that weren't supplied by Mirage Systems, Inc., it is important that they be checked for proper configuration. The side view in the illustration shows a correctly built 3-Ring riser attached to the harness ring and put under moderate tension. Note the following:

- 1) The rings overlap each other and maintain metal-to-metal contact between each other.
- 2) The rings are aligned in parallel planes.
- 3) The smallest ring is not pulled snug against the grommet and the white loop is long enough to give it some play.
- 4) The white locking loop goes straight down through the center of the riser grommet on its way to the cable housing end fitting; it does not extend past the edge of the grommet hole and then turn back upwards towards the hole.

IMPORTANT: If your riser configuration does not match this illustration, the 3-Ring release might not function correctly. You should contact a rigger or Mirage Systems before jumping with those risers.



Assembly of Optional Centerline Collapsible Pilot Chute

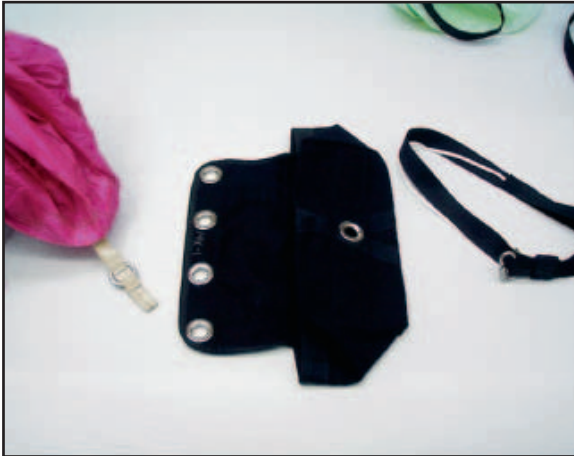

Fig. 1

Set out your main canopy, main bag and new pilot chute. Find the bridle attachment point on your main canopy [Fig. 1].

Remove the #4 Rapid link from the bridle. Be sure to unscrew the barrel fully, that will help you to install it later.



Fig. 2

Feed the end of the bridle through the grommet in the top of the main bag from the outside in. Fold the bridle if necessary and push the two short loops of fabric (one covered in yellow Kevlar tape) through the grommet as well. About 1" (2.5 cm) should protrude through to the inside of the main bag [Fig. 2]



Fig. 3

Guide the open #4 Rapid link through the fabric loop which is backed with yellow Kevlar tape [Fig. 3]

Assembly of Optional Centerline Collapsible Pilot Chute



Fig. 4

Pass the white collapse line and the bridle through the Rapid link by passing them through the open gate of the link. At this point, a small screwdriver or other similar tool can be used to straighten out the second fabric loop [Fig. 4]

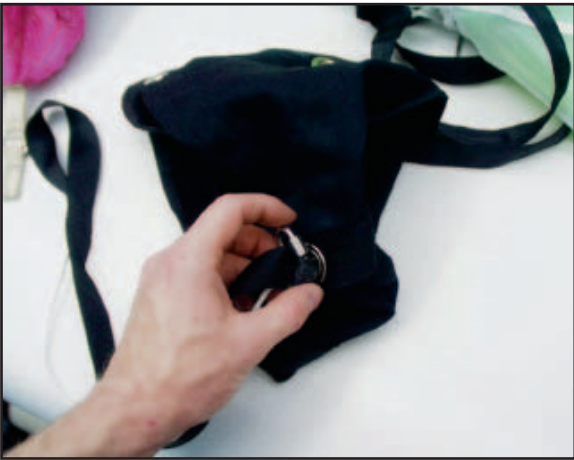

Fig. 5

Feed the male end of the connector link through the gap in the second loop until it protrudes through the loop, then thread the barrel over the male end, closing the link. Tighten lightly with a wrench [Fig. 5]

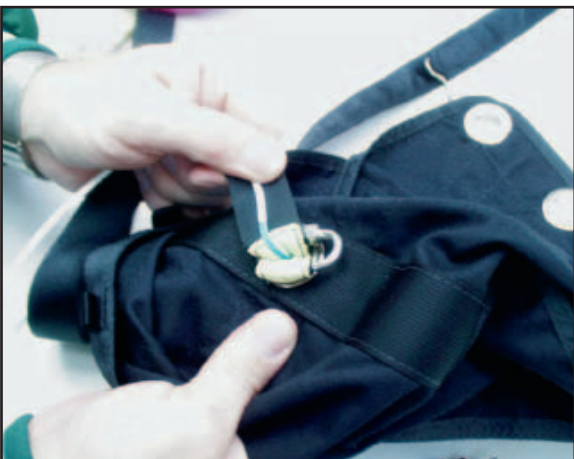

Fig. 6

Now pull the loop material over the barrel so the barrel is covered by the black loop. The collapse line should exit the bridle between Kevlar and the link should lie as shown [Fig. 6]

Assembly of Optional Centerline Collapsible Pilot Chute



Fig. 7

Pass the large loop at the end of the bridle through the canopy bridle attachment loop, then pass the entire assembly, starting with the pilot chute handle through the loop in the bridle. [Fig. 7]



Fig. 8

Cinch tight [Fig. 8]

If these instructions are at all unclear or you have any questions, CONSULT A RIGGER.



IMPORTANT: In order for the collapsing pilot chute to work properly, it must be cocked before every jump. Failure to cock the pilot chute may result in a major malfunction. To cock the pilot chute, pull the pilot chute handle while holding the bridle or stepping on the packed main bag, in order to extract the collapse line from the bridle. When it is safe to use, the bridle will be colored in the window near the pin, not white. Check that the collapse line shows color during a pin check prior to every jump. If in doubt, ASK A RIGGER.

Assembly of Standard Pilot Chute



Fig. 1

Feed the large loop of the bridle through the grommet in the top of the main bag from the outside in. [Fig. 1]



Fig. 2

Pass the large loop at the end of the bridle through the canopy bridle attachment loop, then pass the entire assembly, starting with the pilot chute handle [Fig. 2] through the large loop in the bridle.



Fig. 3

Cinch tight [Fig. 3]

CLOSING THE FLY-OPEN BOC



Fig. 1

Line BOC pouch up with loops on bottom of container and thread cable through alternating loops, locking BOC closed. [Fig. 1]

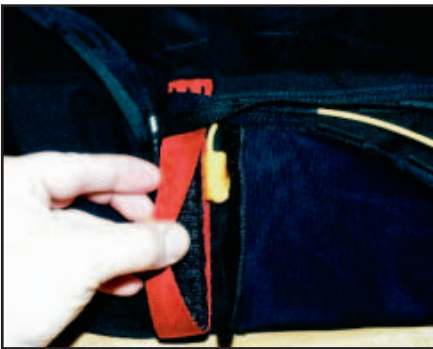

Fig. 2

Insert top of release handle into loop on container, then mate handle to container. [Fig. 2]



Fig. 3

Thread cable end into pocket under right end of BOC pouch. [Fig. 3]



Fig. 4

Ensure main release cable passes through fabric loop on JM release handle. [Fig. 4]

Attaching Main D-Bag and PC



Fig. 1

Turning the main deployment bag inside out, grasp the attachment lanyard at the top of the bag and run it through the loop at the top of the main canopy bridle attachment point. [Fig. 1]



Fig. 2

Push the loop of the attachment lanyard through the grommet at the top of the main bag, holding the canopy bridle attachment point in place. [Fig. 2]



Fig. 3

Turning the bag now right side out, pass the open end of the main bridle through the loop in the bag attachment lanyard. [Fig. 3]



Fig. 4

Pass main PC through the loop in the end of the main bridle. [Fig. 4]



Fig. 5

Draw the bridle through itself and cinch tight. [Fig.5]

Packing the Main Container



Fig. 1

The RTS container system is compatible with practically any ram-air main parachute that will fit into the container. This manual does not provide specific instructions for folding the main canopy; that information must be obtained from the manufacturer's instruction manual for each canopy. Fold the canopy and pack it into the RTS deployment bag according to those instructions. Once you have placed the canopy into the main deployment bag, begin stowing the suspension lines. Start with the center locking stows and work towards the outside. [Fig. 1]

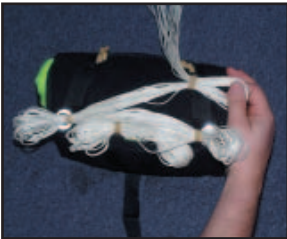

Fig. 2

After making the four locking stows, begin stowing the lines on the center stows. (Fig. 2) Leave approximately 12-15 inches of suspension line unstowed. This will help with straighter openings. [Fig. 3]



Fig. 3

Helpful Hint: Start your lines stows about 2.5 inches long and gradually make them smaller after each row. This helps prevent each line stow from looping over the row before it and causing a malfunction during deployment.



Fig. 4

Lift the bag over the container, making sure that the bag remains straight. Stow the risers alongside the reserve container. Toggles should lie against the reserve container. [Fig. 4]

Helpful Hint: Offsetting the risers side-by-side will reduce bulk in the riser tray and will give the container side a smoother look.

Packing the Main Container



Fig. 5

Lay the secondary riser covers over the risers. Make sure that they are tucked into the riser channel. [Fig. 5]

Helpful Hint: The secondary riser covers are made of a material that will take a shape after use. Take a little extra time on the first 10 pack jobs to insure proper packing of these covers. This extra time will insure the proper shaping of the secondary riser covers, which should not be visible once the main riser covers are packed.



Fig. 6

Thread the pull-up cord. Use the short closing loop in the #1 flap. [Fig. 6]



Fig. 7

Fold back the main container flaps. Place the main bag into the main pack tray.

IMPORTANT: Make sure the line stows go to the bottom of the container [Fig. 7] .

Helpful Hint: To get the best fit into the main container insert the main bag with bridle grommet against the reserve container first, then rotate the bag with the lines towards the bottom of the container. Make sure the bag fills the bottom corners. With the bulk evenly distributed the main container will have a smooth appearance.

Packing the Main Container



Fig. 8

Close flap #2, making sure the main bridle is routed out from under the right side of the #2 flap. Mate the 1" velcro on the bridle line to the 1" velcro on the main flap. Lay excess bridle line to the right. [Fig. 8]



Fig. 9

Close flap #3. [Fig. 9]

Helpful Hint: To help with main container symmetry, keep the main deployment bag centered or a little to the left inside the main pack tray. Pulling on the main flaps while closing has a tendency to push the bag to one side.



Fig. 10

Close Flap #4, and insert closing pin into loop. Tuck and route bridle under #4 flap. Run bridle under bridle protection flap under bottom of container. Check centerline collapsible bridle window to insure that the main pilot chute is cocked. The centerline should show a colored mark, not solid white. [Fig. 10] Stow the bridle under the right main side (#4) flap from near the closing pin down to bottom of the container.

Helpful Hint: No bridle or main pilot chute material should be exposed. Exposed bridle may result in a premature main container opening.

Proper Bridle Routing for Main Container

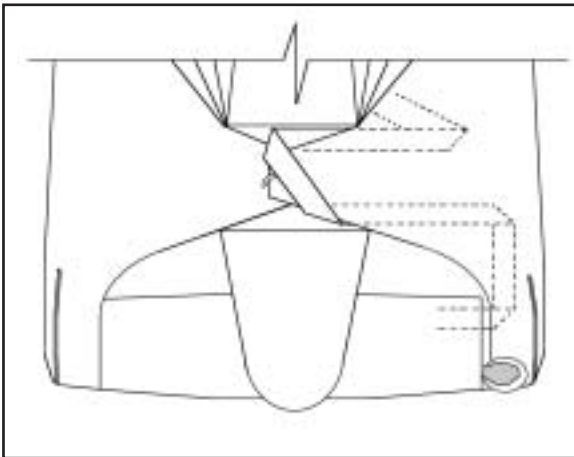

Fig. 1

Proper routing of the main bridle for standard right-handed main deployment [Fig. 1]. Note that the bridle passes from the right of the container to the pin, and back out to the right. It does not cross over the #2 flap.

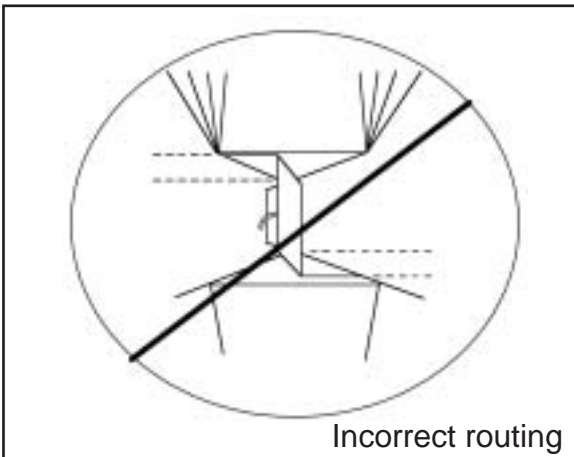

Fig. 2

IMPORTANT: Do not cross the main bridle from left side to right side of the main pin cover flap, as this may cause a slow deployment or a main pilot chute in tow [Fig. 2]. The bridle must be routed on the same side of the main pin cover as the bridle is routed into the main pilot chute pouch.



Main Closing With Ripcord



Fig. 1

Feed ripcord into housing inside BOC pouch opening. [Fig.1]



Fig. 2

With main bag and line stowed, thread long pull-up cord through closing loop in main bag kicker plate. [Fig. 2]



Fig. 3

Thread pull-up cord up through center of main spring and through grommet in the top of main PC. Depress spring and pull fabric from coils. [Fig. 3]

Main Closing With Ripcord



Fig. 4

While keeping careful control over the spring-loaded PC, close the main bottom and top flaps. [Fig. 4]



Fig. 5

Close side flaps and pin. Remove pull-up cord. [Fig. 5]



Fig. 6

Stow excess ripcord in midflap pocket and dress container. [Fig. 6]

Packing the Main Pilot Chute



Fig. 1

There are many ways to fold a main pilot chute. Mirage Systems provides these illustrations to demonstrate one method.



Fig. 2



Fig. 3

Store excess bridle line on the hand deploy pilot chute and leave approximately 8" of bridle length. Fold the pilot chute in half and proceed to fold as in illustrations. [Fig. 1-5]



Fig. 4



Fig. 5

Insert folded main pilot chute in the spandex pouch. [Fig. 6]

Helpful Hint: No bridle or main pilot chute material should be exposed. Exposed bridle may result in a premature main container opening.



Fig. 6

Maintaining Your RTS

INTRODUCTION

Your RTS will last longer, look better and function correctly if it is maintained properly. An RTS actually requires very little maintenance unless it is subjected to unusual conditions such as a jump into salt water or a muddy landing.

INSPECTING YOUR MIRAGE

The best approach to maintaining your rig is to periodically spend a few minutes examining every detail on it. This inspection should be done at least every month. If any wear or damage is found, have it repaired immediately by a qualified rigger. Delaying repairs may result in a malfunction.

PARTICULAR ATTENTION SHOULD BE GIVEN TO THESE AREAS:

1 Breakaway System. Refer to the 3-Ring maintenance section in this manual for detailed information on inspecting the canopy releases.

2 Reserve System. This includes the reserve ripcord, locking loop, pins, handle, housing, container and associated stitching. You should not attempt any repairs or modifications to any of these items unless you are a master rigger. You can, however, spot little problems before they become major.

3 Harness. The harness should be inspected periodically for broken stitching or frayed webbing. Main risers, in particular, are subject to wear. See the 3-Ring maintenance section of this manual. Type 17 mini risers should be replaced every 200-400 jumps depending on wing loading.

4 Main Container. Inspect the plastic stiffeners in the container flaps and replace any that are broken. Replace any grommets that are badly deformed or are pulling out of their setting. Replace any worn out spandex pouches, which could result in a premature deployment

5 Main Pilot Chute. Check the center line (the length of nylon tape inside the pilot chute that extends from the handle to the base) of the main pilot chute. It must be firmly sewn at each end; there must be no broken stitches or torn fabric. Inspect the seam that joins the pilot chute mesh to the pilot chute fabric. If the mesh is torn or badly frayed, replace the pilot chute. If your RTS is equipped with a collapsing main pilot chute, look for wear in moving parts.

6 Closing Loop. The main container is held shut with a closing loop made of nylon suspension line sheathing. This loop is subject to wear. If it wears out and breaks, the main canopy may release prematurely and a malfunction may result. Replace the loop with a duplicate if wear is noticed.

CAUTION: **Never jump an RTS with a worn main or reserve closing loop.**

Maintaining Your RTS

YOUR RTS IS MANUFACTURED MOSTLY FROM NYLON. NYLON IS VERY DURABLE, BUT IS SUSCEPTIBLE TO DAMAGE FROM SEVERAL SOURCES:

1 Sunlight. The ultraviolet rays in sunlight quickly and permanently weaken nylon. Keep your RTS out of direct sunlight as much as possible.

2 Acids. Nylon is also damaged by acids. Keep your RTS away from hangar floors, dirty car trunks and similar areas where acids may be found. If such contamination does occur, immediately and thoroughly wash the rig with plenty of warm soapy water. Until a rig can be washed, baking soda will quickly neutralize most acids. If acid damage occurs or is suspected, a rigger should thoroughly inspect your RTS. When not in use, your RTS should be stored in an appropriate storage bag.

3 Oils and Grease. Most petroleum compounds do not weaken nylon; they simply stain it. Such stains should be promptly removed by a rigger using the proper petroleum solvent. Dry cleaning fluid works well.

4 Water. Water will not structurally damage your RTS, but prolonged agitation in clear water weakens webbing or may cause some fabric and tape colors to run. Salt water may damage nylon and rust hardware if not promptly and thoroughly washed off with plenty of fresh water. Your rig will maintain its new appearance longer if it is kept dry. When washing your rig, be gentle with it. Use Woolite or similar mild soap and warm water.

5 Soil. Soil may damage your RTS. Brush off the soil after it has dried and gently wash with warm soapy water. Be sure that the soil is not in the housings, snaps, 3-Ring release or reserve ripcord pins or loops. Consult a rigger if your rig is heavily soiled.

6 Sand. Fine sand will weaken and cut webbing and fabrics of all kinds. Prolonged exposure to sand will shorten the life of the entire parachute assembly.

7 Abrasion. Nylon quickly frays if dragged over concrete or other rough surfaces. Do not drag your rig on the concrete while packing.

Mirage Systems suggests having the container washed every 500 jumps to remove any sand particles. Sand has sharp edges and accelerates wear.

Remember: A well maintained container is a safer container.

Replacement Parts

Components on any device tend to wear out with repeated use. Risers and pilot chutes are limited lifetime components. With repeated use the materials break down, losing their structural integrity. Other parts such as breakaway handles, reserve ripcords, reserve pilot chutes and reserve freebags at times are lost after an emergency procedure. Container size and serial numbers are necessary to insure that the proper replacement part is ordered. Please check with your dealer on the current replacement part prices.

Fig. 1



If you are ordering replacement risers that are different from what you currently have please give the length (20", 22", 24"), color, webbing type (mini or large), toggle type (Velcro, Velcroless), and hardware type (standard or stainless steel) [Fig. 1]



Fig. 2

When ordering a main pilot chute different from the original, please provide the following information: what type (standard or centerline collapsible), and what type of handle (plastic or leather hacky). Centerline pilot chutes and hackys require color choices. [Fig. 2]

Fig.



The standard color for breakaway handles is red. Other colors are available. Embroidery is also available on the handle. RTS replacement breakaway handles are stock lengths, they must be cut to proper length upon delivery. [Fig. 3]

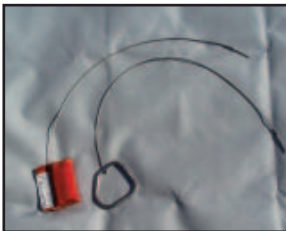

Fig. 4

Reserve ripcords come in different lengths. Rig size and serial numbers are very important when ordering replacement ripcords. Please specify type of ripcord. (Standard metal RTS handle or the soft reserve ripcord handle.) [Fig. 4]



Fig. 5

Reserve freebag and reserve pilot chutes are sometimes lost after the deployment of the reserve container. When replacing these parts, the container size and serial number are critical. [Fig. 5]

User Instructions

HOW TO PUT THE HARNESS/CONTAINER ON.

When putting on your RTS, first place your arms through the main lift web. The container should be resting on your shoulders. [Fig.1]



Fig 1

Next, slip the leg straps on. Tighten the leg straps until they fit comfortably. [Fig. 2]

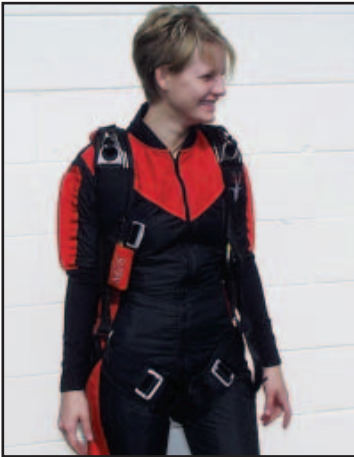

Fig 2

IMPORTANT: Make sure the leg strap is threaded properly through the friction adapter. If you have any questions consult your rigger or instructor.

Helpful Hint: Leaning forward slightly while tightening will provide an even tighter fit. The container tends to slide down the back before the leg straps are tightened. Leaning forward while cinching the leg straps allows the user to move the container further up their back. [Fig. 3]

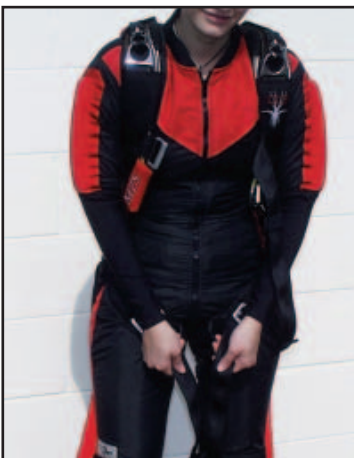

Fig 3

User Instructions



Fig 4

Thread the chest strap through the friction adapter. Tighten until comfortable. [Fig. 4]



Fig 5

IMPORTANT: Make sure the chest strap is threaded properly through the friction adapter. If you have any questions consult your rigger or instructor. [Fig. 5]



Fig 6

Once you have the leg and chest strap tightened, stow all excess webbing away. Excess webbing can cause an entanglement during deployment or could be grabbed inadvertently. [Fig.6]

Remove the harness/container by reversing this process.

IMPORTANT: This manual does not replace proper training and equipment orientation.

RTS HARNESS / CONTAINER SYSTEM

RTS

**MIRAGE SYSTEMS, INC.
POST OFFICE BOX 820
DELAND, FL 32721**

**SHIPPING ADDRESS:
1301 A LEXINGTON AVE.
DELAND, FL 32724**

WWW.MIRAGESYS.COM

PHONE: 386-740-9222 FAX: 386-740-9444

MIRAGE SYSTEMS